

NAS System

User's Manual

Revision 1.1

Before You Begin

Before going through with this manual, you should read and focus on the following safety guidelines. Information about the NAS system's packaging and delivery are also included. To provide reasonable protection against any harm on the part of the user and to obtain maximum performance, user is advised to be aware of the following safety guidelines particularly in handling hardware components:

Upon receiving of the product:

- ❖ Place the product in its proper location.
- ❖ To avoid unnecessary dropping out, make sure that somebody is around for immediate assistance.
- ❖ It should be handled with care to avoid dropping that may cause damage to the product. Always use the correct lifting procedures.

Upon installing of the product:

- ❖ Ambient temperature is very important for the installation site. It must not exceed 30°C. Due to seasonal climate changes; regulate the installation site temperature making it not to exceed the allowed ambient temperature.
- ❖ Before plugging-in any power cords, cables and connectors, make sure that the power switches are turned off. Disconnect first any power connection if the power supply module is being removed from the enclosure.
- ❖ Outlets must be accessible to the equipment.
- ❖ All external connections should be made using shielded cables and as much as possible should not be performed by bare hand. Using anti-static hand gloves is recommended.
- ❖ In installing each component, secure all the mounting screws and locks. Make sure that all screws are fully tightened. Follow correctly all the listed procedures in this manual for reliable performance.

Controller Configuration

This NAS system supports single RAID controller configuration.

Packaging, Shipment and Delivery

- ❖ Before removing the subsystem from the shipping carton, you should visually inspect the physical condition of the shipping carton.
- ❖ Unpack and verify that the contents of the shipping carton are complete and in good condition.
- ❖ Exterior damage to the shipping carton may indicate that the contents of the carton are damaged.
- ❖ If any damage is found, do not remove the components; contact the dealer where you purchased the subsystem for further instructions.

Table of Contents

Before You Begin	2
Chapter 1 Introduction.....	4
1.1 Key Features.....	4
1.2 Technical Specifications	5
1.3 RAID Concepts	6
1.4 Array Definition.....	10
1.4.1 Raid Set.....	10
1.5 High Availability.....	11
1.5.1 Creating Hot Spares.....	11
1.5.2 Hot-Swap Disk Drive Support.....	11
1.5.3 Hot-Swap Disk Rebuild.....	11
Chapter 2 Getting Started	12
2.1 Packaging, Shipment and Delivery.....	12
2.2 Unpacking the NAS System.....	12
2.3 Identifying Parts of the NAS System.....	13
2.3.1 Front View.....	13
2.3.1.1 Disk Trays.....	14
2.3.1.2 LCD Front Panel	15
2.3.2 Rear View.....	17
Chapter 3 Getting Started with the NAS System.....	18
3.1 Connecting the NAS to your Network.....	18
3.2 Powering On	18
3.3 Installing Hard Drives.....	19
3.3.1 Installing 3.5" Disk in a Disk Tray.....	19
3.3.2 Installing 2.5" Disk in a Disk Tray.....	21

Chapter 1 Introduction



The NAS System

1.1 Key Features

- Configurable to 19" rack-mountable 2U chassis
- Supports up to eight (8) 2.5"/3.5" hot-swappable 6Gb/s SAS/SATA hard drives
- Supports RAID levels 0, 1, 5, 6, 10, 50
- Support Smart-functional LCD panel
- Support drive hot spare and automatic hot rebuild
- Centralization of Data and Storage Management
- Real-time drive activity and status indicators
- Environmental monitoring unit
- Allow online capacity expansion within the enclosure
- Locally audible event notification alarm

1.2 Technical Specifications

Hardware Platform
Intel Celeron 2.8GHz CPU or above
Cache memory : 8GB DDR4 up to 32GB
Four USB3.0 and Two USB2.0 ports
Two Gigabit Ethernet ports
Up to Eight 2.5"/3.5" hot-swappable 6Gb/s SAS/SATA hard drives
Real-time drive activity and status indicators
Environmental monitoring unit
Two(2) 460W 80plus hot-swap power supplies with PFC
RAID Controller
Highpoint RocketRAID 2720
Support RAID level: RAID 0, 1, 5, 6, 10, 50
Support drive hot spare and automatic hot rebuild
Allow online capacity expansion within the enclosure
Locally audible event notification alarm
Power requirements
AC 100V ~ 240V Full range
10A ~ 5A, 47~63Hz
Environmental
Relative humidity : 10%~85% Non-condensing
Operating temp : 10°C~40°C(50°F~104°F)
Physical Dimension
88(H) x 482(W) x 500(D)mm

Specifications are subject to change without notice.

1.3 RAID Concepts

RAID Fundamentals

The basic idea of RAID (Redundant Array of Independent Disks) is to combine multiple inexpensive disk drives into an array of disk drives to obtain performance, capacity and reliability that exceeds that of a single large drive. The array of drives appears to the host computer as a single logical drive.

Five types of array architectures, RAID 1 through RAID 5, were originally defined; each provides disk fault-tolerance with different compromises in features and performance. In addition to these five redundant array architectures, it has become popular to refer to a non-redundant array of disk drives as a RAID 0 arrays.

Disk Striping

Fundamental to RAID technology is striping. This is a method of combining multiple drives into one logical storage unit. Striping partitions the storage space of each drive into stripes, which can be as small as one sector (512 bytes) or as large as several megabytes. These stripes are then interleaved in a rotating sequence, so that the combined space is composed alternately of stripes from each drive. The specific type of operating environment determines whether large or small stripes should be used.

Most operating systems today support concurrent disk I/O operations across multiple drives. However, in order to maximize throughput for the disk subsystem, the I/O load must be balanced across all the drives so that each drive can be kept busy as much as possible. In a multiple drive system without striping, the disk I/O load is never perfectly balanced. Some drives will contain data files that are frequently accessed and some drives will rarely be accessed.

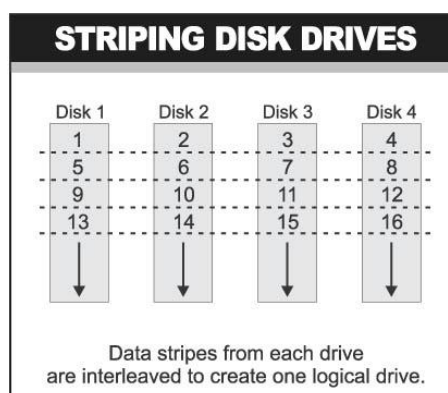

By striping the drives in the array with stripes large enough so that each record falls entirely within one stripe, most records can be evenly distributed across all drives. This keeps all drives in the array busy during heavy load situations. This situation allows all drives to work concurrently on different I/O operations, and thus maximize the number of simultaneous I/O operations that can be performed by the array.

Definition of RAID Levels

RAID 0 is typically defined as a group of striped disk drives without parity or data redundancy. RAID 0 arrays can be configured with large stripes for multi-user environments or small stripes for single-user systems that access long sequential records. RAID 0 arrays deliver the best data storage efficiency and performance of any array type. The disadvantage is that if one drive in a RAID 0 array fails, the entire array fails.

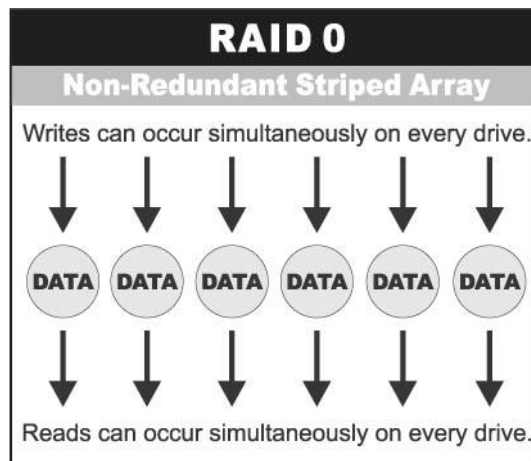

RAID 1, also known as disk mirroring, is simply a pair of disk drives that store duplicate data but appear to the computer as a single drive. Although striping is not used within a single mirrored drive pair, multiple RAID 1 arrays can be striped together to create a single large array consisting of pairs of mirrored drives. All writes must go to both drives of a mirrored pair so that the information on the drives is kept identical. However, each individual drive can perform simultaneous, independent read operations. Mirroring thus doubles the read performance of a single non-mirrored drive and while the write performance is unchanged. RAID 1 delivers the best performance of any redundant array type. In addition, there is less performance degradation during drive failure than in RAID 5 arrays.

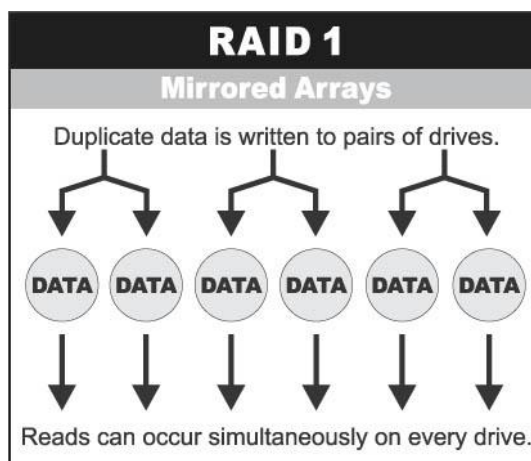

Under **RAID 5** parity information is distributed across all the drives. Since there is no dedicated parity drive, all drives contain data and read operations can be overlapped on every drive in the array. Write operations will typically access one data drive and one parity drive. However, because different records store their parity on different drives, write operations can usually be overlapped.

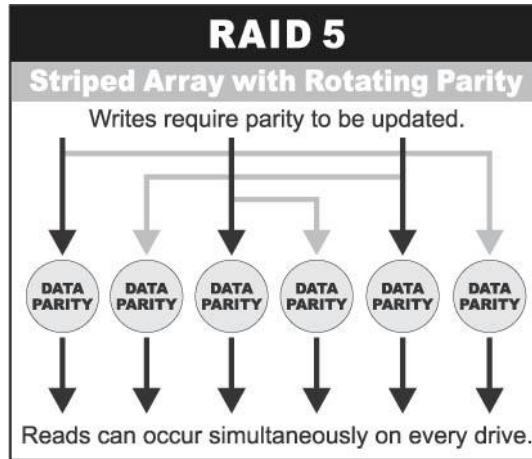

Dual-level RAID achieves a balance between the increased data availability inherent in RAID 1 and RAID 5 and the increased read performance inherent in disk striping (RAID 0). These arrays are sometimes referred to as RAID 0+1 or RAID 10 and RAID 0+5 or RAID 50.

RAID 6 is similar to RAID 5 in that data protection is achieved by writing parity information to the physical drives in the array. With RAID 6, however, **two** sets of parity data are used. These two sets are different, and each set occupies a capacity equivalent to that of one of the constituent drives. The main advantage of RAID 6 is High data availability – any two drives can fail without loss of critical data.

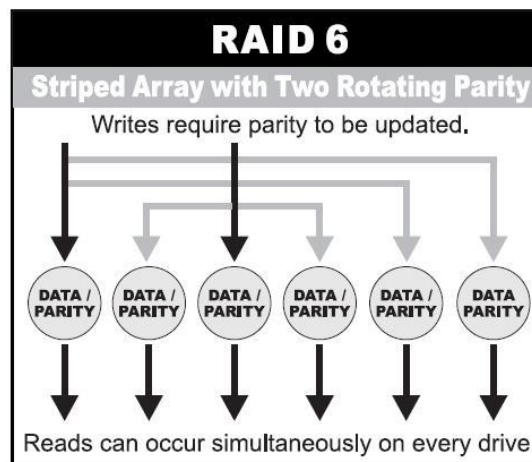

In summary:

- ♦ RAID 0 is the fastest and most efficient array type but offers no fault-tolerance. RAID 0 requires a minimum of one drive.
- ♦ RAID 1 is the best choice for performance-critical, fault-tolerant environments. RAID 1 is the only choice for fault-tolerance if no more than two drives are used.
- ♦ RAID 5 combines efficient, fault-tolerant data storage with good performance characteristics. However, write performance and performance during drive failure is slower than with RAID 1. Rebuild operations also require more time than with RAID 1 because parity information is also reconstructed. At least three drives are required for RAID 5 arrays.
- ♦ RAID 6 is essentially an extension of RAID level 5 which allows for additional fault tolerance by using a second independent distributed parity scheme (two-dimensional parity). Data is striped on a block level across a set of drives, just like in RAID 5, and a second set of parity is calculated and written across all the drives; RAID 6 provides for an extremely high data fault tolerance and can sustain multiple simultaneous drive failures. It is a perfect solution for mission critical applications.

RAID Management

The subsystem can implement several different levels of RAID technology. RAID levels supported by the subsystem are shown below.

RAID Level	Description	Min. Drives
0	Block striping is provided, which yields higher performance than with individual drives. There is no redundancy.	1
1	Drives are paired and mirrored. All data is 100% duplicated on an equivalent drive. Fully redundant.	2
5	Data is striped across several physical drives. Parity protection is used for data redundancy.	3
6	Data is striped across several physical drives. Parity protection is used for data redundancy. Requires N+2 drives to implement because of two-dimensional parity scheme.	4
10	Combination of RAID levels 1 and 0. This level provides redundancy through mirroring and striping. RAID 10 requires the use of an <u>even number</u> of disk drives to achieve data protection.	4
50	RAID 50 provides the features of both RAID 0 and RAID 5. RAID 50 includes both parity and disk striping across multiple drives. RAID 50 is best implemented on two RAID 5 disk arrays with data striped across both disk arrays.	6

1.4 Array Definition

1.4.1 Raid Set

A Raid Set is a group of disk drives with RAID Level. It is basically a logical disk (RAID disk) which appears to the NAS system as SCSI disk device, such as /dev/sdb.

1.5 High Availability

1.5.1 Creating Hot Spares

A hot spare drive is an unused online available drive, which is ready to replace a failed disk drive. In a RAID level 1, 10, or 5 Raid Set, any unused online available drive installed but not belonging to a Raid Set can be defined as a hot spare drive. Hot spares permit you to replace failed drives without powering down the system. When the RAID subsystem detects a drive failure, the system will do automatic and transparent rebuild using the hot spare drives. The Raid Set will be reconfigured and rebuilt in the background while the RAID subsystem continues to handle system request. During the automatic rebuild process, system activity will continue as normal, however, the system performance and fault tolerance will be affected.



IMPORTANT: The hot spare must have at least the same or bigger capacity than the drive it replaces.

1.5.2 Hot-Swap Disk Drive Support

The RAID subsystem has built-in protection circuit to support the replacement of hard disk drives without having to shut down or reboot the system. The removable hard drive tray can deliver "hot swappable" fault-tolerant RAID solution at a price much less than the cost of conventional hard disk RAID subsystems. This feature is provided in the RAID subsystem for advance fault tolerant RAID protection and "online" drive replacement.

1.5.3 Hot-Swap Disk Rebuild

The Hot-Swap feature can be used to rebuild Raid Sets with data redundancy such as RAID level 1, 10, and 5. If a hot spare is not available, the failed disk drive must be replaced with a new disk drive so that the data on the failed drive can be rebuilt. If a hot spare is available, the rebuild starts automatically when a drive fails. The RAID subsystem automatically and transparently rebuilds failed drives in the background.





Chapter 2 Getting Started

2.1 Packaging, Shipment and Delivery

- ❖ Before removing the subsystem from the shipping carton, you should visually inspect the physical condition of the shipping carton.
- ❖ Unpack and verify that the contents of the shipping carton are complete and in good condition.
- ❖ Exterior damage to the shipping carton may indicate that the contents of the carton are damaged.
- ❖ If any damage is found, do not remove the components; contact the dealer where you purchased the subsystem for further instructions.

2.2 Unpacking the NAS System

The package contains the following items:

NAS System Unit	
Two (2) power cords	
Two (2) Ethernet LAN cables	
Spare screws, etc.	

If any of these items are missing or damaged, please contact your dealer or sales representative for assistance.

2.3 Identifying Parts of the NAS System

The illustrations below identify the various parts of the subsystem.

2.3.1 Front View

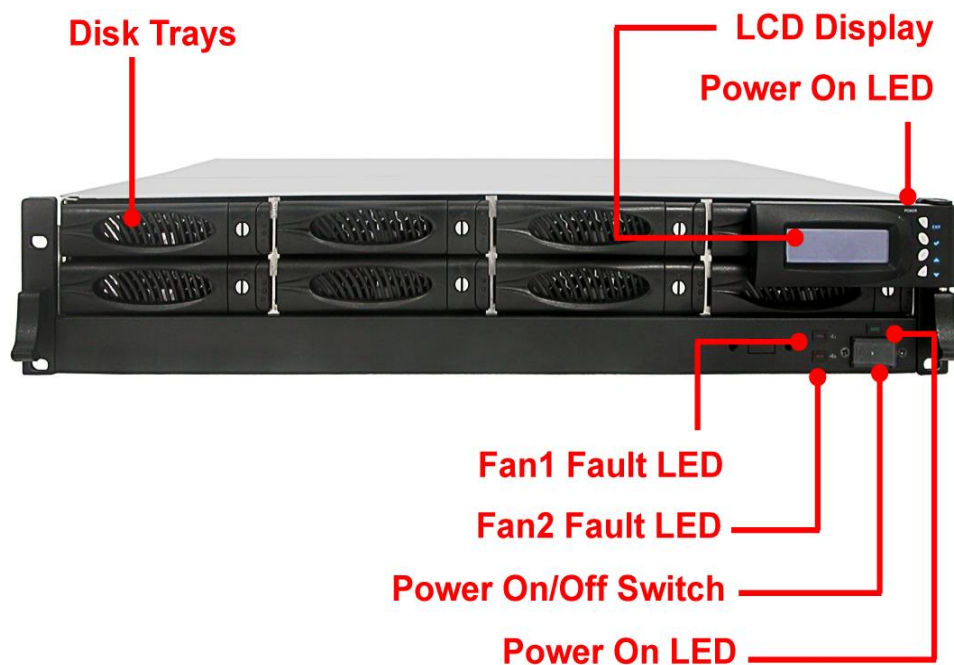

Power LED – LED is green when the NAS system is on.

Fan1, Fan2 Fault LED – LED is red when Fan1 or Fan2 fails.

Power On/Off Switch – Use this switch to power on or power off the NAS system.



2.3.1.1 Disk Trays



HDD Status Indicator

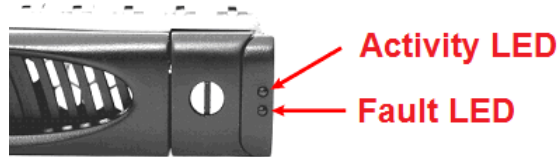

Part	Function
HDD Activity LED	This LED will blink blue when the hard drive is being accessed.
HDD Fault LED	Green LED indicates power is on and hard drive status is good for this slot. If hard drive is defective or failed, the LED is Red. LED is off when there is no hard drive.

Lock Indicator

Every Disk Tray is lockable and is fitted with a lock indicator to indicate whether or not the tray is locked into the chassis or not. Each tray is also fitted with an ergonomic handle for easy tray removal.

When the Lock Groove is horizontal, this indicates that the Disk Tray is locked. When the Lock Groove is vertical, then the Disk Tray is unlocked.

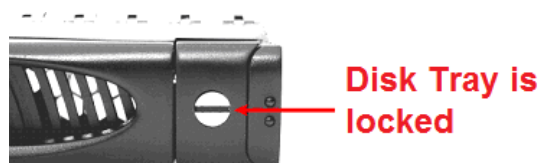
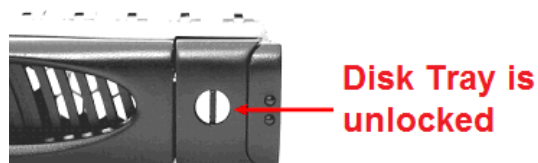



2.3.1.2 LCD Front Panel



Front Panel

The LCD front panel is an option to setup some system settings. To start using the LCD panel, press the Select button to login and configure the system. See the LCD menu diagram in the next section.

Parts	Function
Exit button EXIT	Press this button to return to the previous menu.
Select button 	This is used to enter the option you have selected.
Up and Down Arrow buttons 	Use the Up or Down arrow keys to go through the information on the LCD screen. This is also used to move between each menu when you configure the system.

Menu Diagram

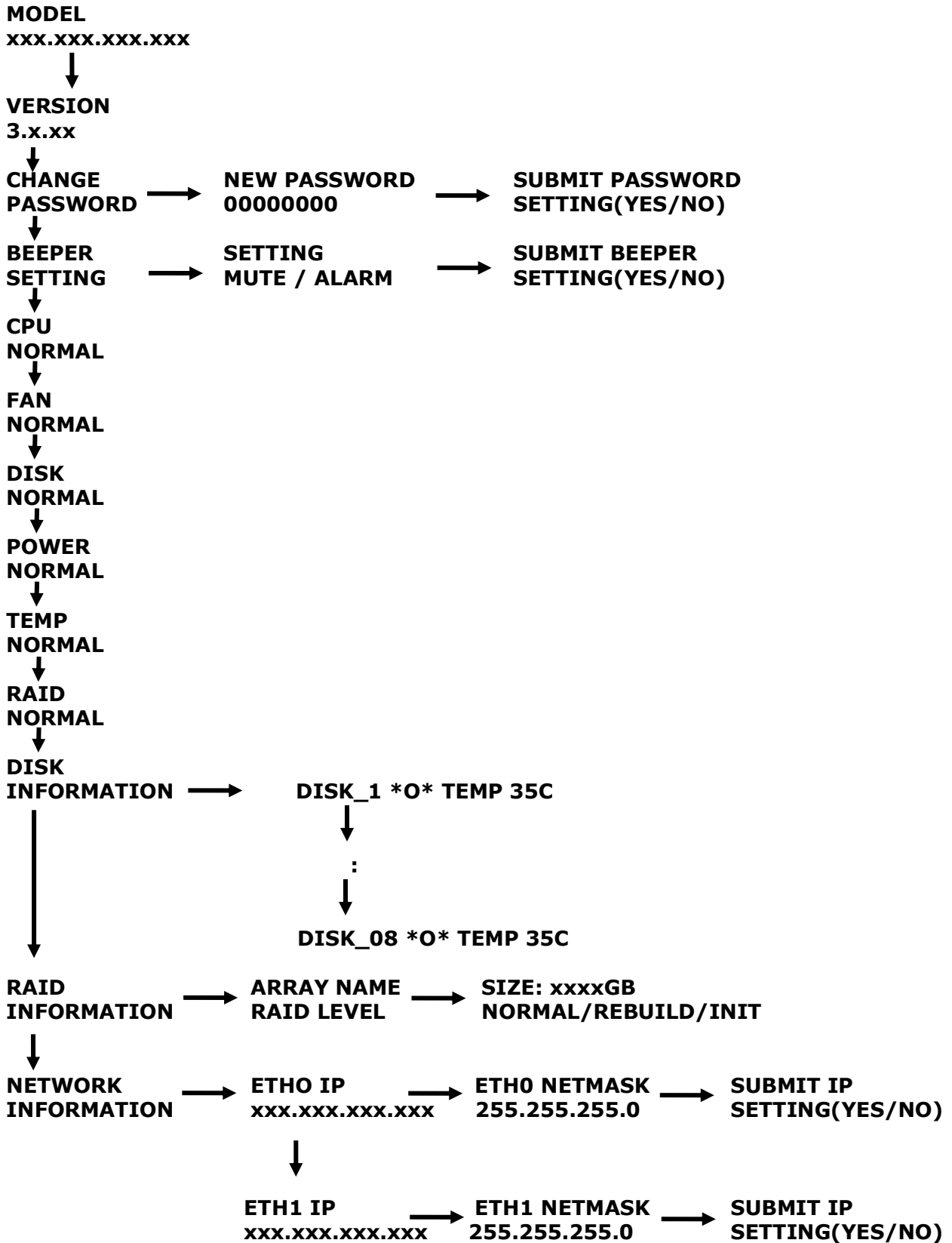

2.3.2 Rear View

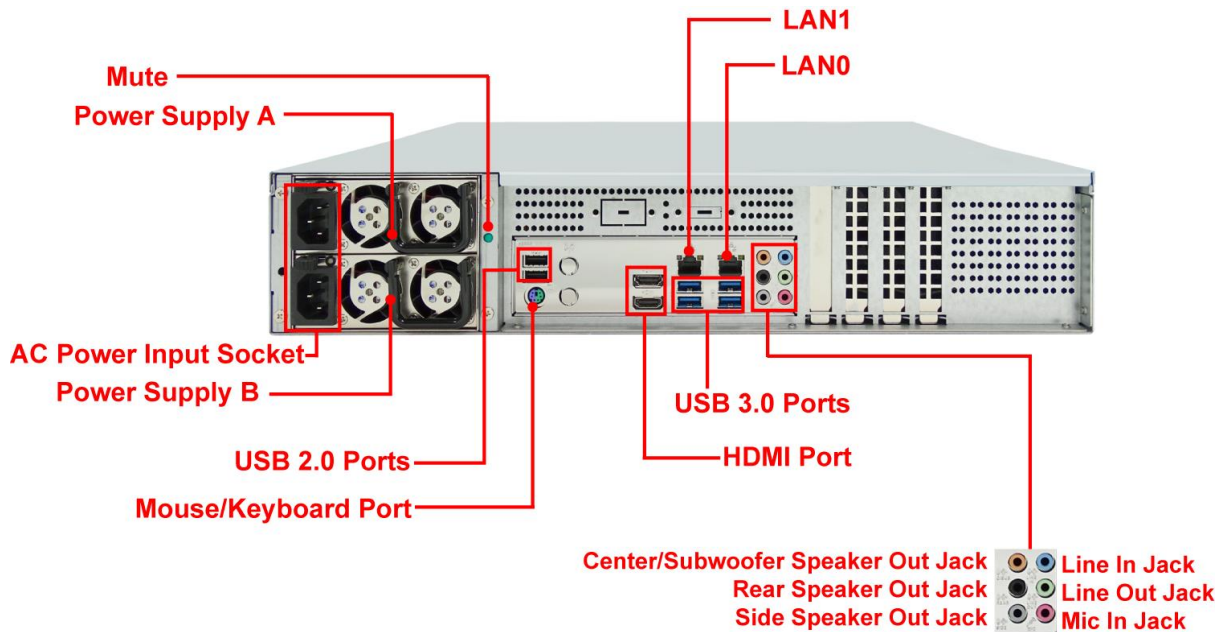

1. **AC Power Input Socket** – Use this to plug in the power cable connected from power source.
2. **Power Supply A, B** – Two power supplies PSU-A and PSU-B are located at the rear of the NAS System.
3. **Mute** – Use the mute button to stop the power supply buzzer alarm.
4. **USB 2.0 ports** – Two USB 2.0 ports are located at the rear of the system.
5. **HDMI Port** - Two HDMI ports are located at the rear of the system. HDMI (High-Definition Multimedia Interface) is an all-digital audio/video interface capable of transmitting uncompressed audio/video signals.
6. **USB 3.0 Port** – Four USB 3.0 ports are located at the rear of the system. The USB 3.0 port supports the USB 3.0 specification and is compatible to the USB 2.0/1.1 specification.
7. **LAN Ports** – The system comes with two 1Gigabit Ethernet ports LAN0 and LAN1.

Chapter 3 Getting Started with the NAS System

3.1 Connecting the NAS to your Network

Attach network cable to the Ethernet port LAN0. Connect the other end to your network hub or switch. You may also connect the other Ethernet port if needed.

3.2 Powering On

1. Plug in the 2 power cords into the AC Power Input Socket located at the rear of the NAS system.



NOTE: The NAS system is equipped with redundant, full range power supplies with PFC (power factor correction). The system will automatically select voltage.

2. Open the protective cover of the Power On/Off Switch at the front of the NAS system.



3. Turn on the Power On/Off Switch to power on the NAS.
4. The Power LED on the front Panel will turn green.

3.3 Installing Hard Drives

This section describes the physical locations of the hard drives supported by the subsystem and gives instructions on installing a hard drive. The subsystem supports hot-swapping allowing you to install or replace a hard drive while the subsystem is running.

Each Drive Carrier has a locking mechanism. When the Lock Groove, which is located in carrier open button, is horizontal, the Drive Carrier is locked. When the Lock Groove is vertical, the Drive Carrier is unlocked. Lock and unlock the Drive Carriers by using a flat-head screw driver.

3.3.1 Installing 3.5" Disk in a Disk Tray

- a. Make sure the lock indicator is in unlocked position. To pull out a disk tray, press the tray open button.



- b. Pull out an empty disk tray. Pull the lever handle outwards to remove the carrier from the enclosure.
- c. Place the hard drive in the disk tray.



- d. Install the mounting screws on the bottom part to secure the drive in the disk tray.



Tray Hole A

- e. Slide the tray into a slot.
- f. Close the lever handle until you hear the latch click into place.

3.3.2 Installing 2.5" Disk in a Disk Tray

- a. Make sure the lock indicator is in unlocked position. To pull out a disk tray, press the tray open button.



- b. Pull out an empty disk tray. Pull the lever handle outwards to remove the carrier from the enclosure.

- c. Place the 2.5" hard drive in the disk tray.



- d. Install the mounting screws on the bottom part to secure the drive in the disk tray.

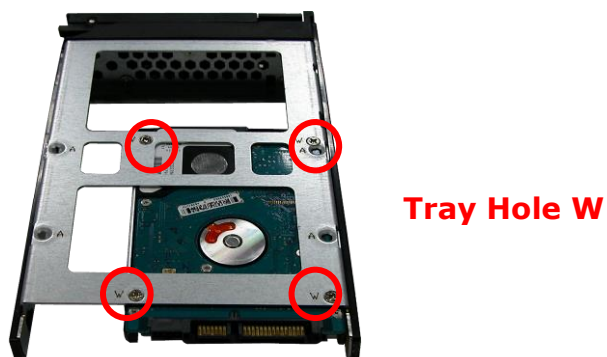

- e. Slide the tray into a slot.
- f. Close the lever handle until you hear the latch click into place.