

SAS JBOD

16-bay Rackmount
Enclosure

Installation Reference Guide

Revision 1.0

P/N: PW002000000281

Copyright

No part of this publication may be reproduced, stored in a retrieval system, or transmitted in any form or by any means, electronic, mechanical, photocopying, recording or otherwise, without the prior written consent.

Trademarks

All products and trade names used in this document are trademarks or registered trademarks of their respective holders.

Changes

The material in this documents is for information only and is subject to change without notice.

FCC Compliance Statement

This equipment has been tested and found to comply with the limits for a Class B digital device, pursuant to Part 15 of the FCC rules. These limits are designed to provide reasonable protection against harmful interference in residential installations. This equipment generates, uses, and can radiate radio frequency energy, and if not installed and used in accordance with the instructions, may cause harmful interference to radio communications. However, there is not guarantee that interference will not occur in a particular installation. If this equipment does cause interference to radio or television equipment reception, which can be determined by turning the equipment off and on, the user is encouraged to try to correct the interference by one or more of the following measures:

1. Reorient or relocate the receiving antenna
2. Move the equipment away from the receiver
3. Plug the equipment into an outlet on a circuit different from that to which the receiver is powered.
4. Consult the dealer or an experienced radio/television technician for help

All external connections should be made using shielded cables.



About This Manual

Welcome to your **SAS JBOD** enclosure User's Guide. This manual covers everything you need to know in learning how to install your JBOD enclosure. It includes the following information :

Chapter 1 **Introduction**

Introduces you to JBOD enclosure's features.

Chapter 2 **Getting Started**

Helps user to identify parts of the JBOD enclosure and prepare the hardware for installation.

Chapter 3 **Maintenance**

Environment Monitor & Configure

Describes Environmental Monitor & Configure information in more detail.

Updating Firmware

Helps user to update the firmware to the latest version.

Hot Swap Components

Describes all hot swap modules on enclosure and provides the detailed procedure to replace them.

Table of Contents

Chapter 1 Introduction

1.1	Technical Specification.....	1-1
-----	------------------------------	-----

Chapter 2 Getting Started

2.1	Unpacking the enclosure.....	2-1
2.2	Identifying Parts of the enclosure.....	2-3
	2.2.1 Front View.....	2-3
	2.2.2 Rear View.....	2-5
2.3	Connecting to Host.....	2-7
2.4	Install Hard Drives.....	2-8
2.5	Powering-on the enclosure.....	2-10

Chapter 3 Maintenance

3.1	Environment Monitor & Configure.....	3-1
3.2	Hot Swap components.....	3-5
3.3	Hot Swap components.....	3-6
	3.3.1 Replacing a disk.....	3-6
	3.3.2 Replacing a Power Supply.....	3-7
	3.3.3 Replacing a Fan.....	3-8

Chapter 1

Introduction

The 16-bay enclosures are designed to be used with a host system to provide a high-end subsystem. The 16-bay SAS JBOD Rackmount is a 19" wide, 3U (5-1/4") high rackmount enclosure that supports up to sixteen(16) 1-inch SAS/SATA drives.

1.1 Technical Specification

Form-factor	3U 19-inch rackmount chassis
Host bus interface	one 4x mini SAS (SFF-8088)
Drive bus interface	3Gb/s SAS or SATA II
Expansion	two 4x mini SAS (SFF-8088)
Hot-swap drive trays	sixteen (16) 1-inch trays
Hot-swappable power supplies	Two (2) 460W power supplies w/ PFC
Cooling fans	4
Disk Slot Temperature	Yes (16 Slot)
FAN Status	Yes
Power Supply status	Yes
Voltage Detect	Yes
SES support	Yes
Power requirements	AC 90V~264V Full Range 8A ~ 4A, 47Hz~63Hz

Chapter 2

Getting Started

Getting started with the enclosure consists of the following steps:

- ❖ *Unpack the JBOD enclosure.*
- ❖ *Identifying Parts of the enclosure.*
- ❖ *Connecting to Host.*
- ❖ *Install Hard Drives.*
- ❖ *Power on the enclosure.*

2.1 Unpacking the enclosure

Before continuing, first unpack the enclosure and verify that the contents of the shipping carton are all there and in good condition. Before removing the enclosure from the shipping carton, visually inspect the physical condition of the shipping carton. Exterior damage to the shipping carton may indicate that the contents of the carton are damaged. If any damage is found, do not remove

the components; contact the dealer where the enclosure was purchased for further instructions.

The package contains the following items:

- 3U Rackmount enclosure unit
- Two power cords
- One external SAS cable
- One external null modem cable
- Installation Reference Guide
- Spare screws, etc.

If any of these items are missing or damaged, please contact your dealer or sales representative for assistance.



2.2 Identifying Parts of the enclosure

The illustrations below identify the various features of the enclosure. Get yourself familiar with these terms as it will help you when you read further in the following sections.

2.2.1 Front View

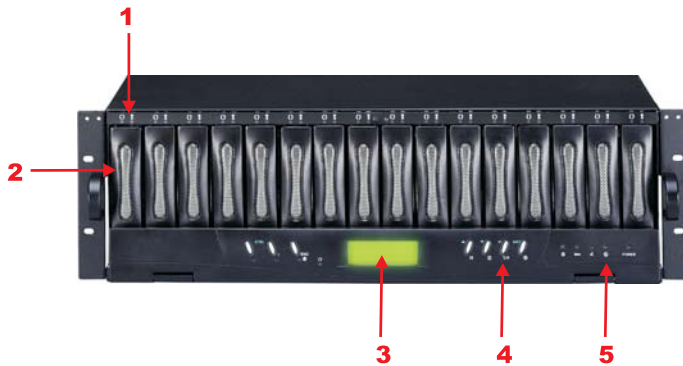

1. HDD status Indicator



Parts	Function
HDD Status LEDs ● ✕	Green LED indicates power is on and hard drive status is good for this slot. If there is no hard drive, the LED is red. If hard drive defected in this slot or the hard drive is failure, the LED is blinking red.
HDD access LEDs ↻	These LED will blink blue when the hard drive is being accessed.

2. HDD trays 1 ~ 16 (From right to left)

3. LCD display panel

4. Smart Function Panel - Function Key

The smart LCD panel is where you will monitor the enclosure status.

5. Environment status

2.2.2 Rear View

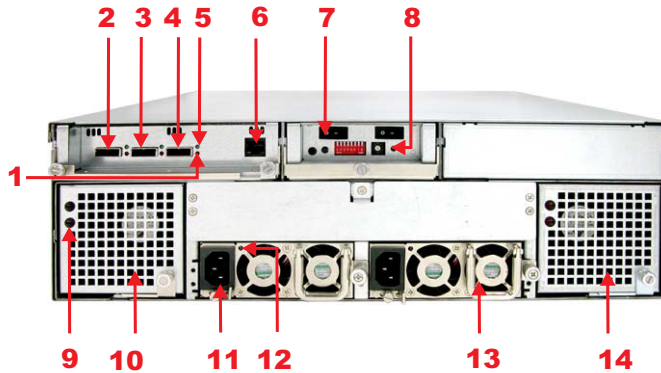

1. Expander Access LED

These LEDs will blink blue when the expander is being accessed.

2. SAS Expansion Port

3. SAS in Port

The SAS In port is used to connect to a host.

4. SAS Expansion Port

5. Expander Link LED

Green LED indicates Expander is linking.

6. Monitor Port

The Enclosure is equipped with a serial monitor port allowing you to connect a PC or terminal.

7. Power Supply Unit on / off switch

8. System Power On Indicator

Green LED indicates power is on.

9. Fan Fail indicator

If a fan fails, this LED will turn red.

10. Cooling Fan module 1 ~ 2

Two blower fans are located at the rear of the Enclosure. They provide sufficient airflow and heat dispersion inside the chassis. In case a fan fails to function, the “” Fan fail LED will turn red and an alarm will sound.

11. AC power input socket 1 ~ 2 (From left to right)

12. Power Supply Power On Indicator

Green LED indicates power is on.

13. Power Supply Unit 1 ~ 2 (From left to right)

Two power supplies (power supply 1 and power supply 2) are located at the rear of the Enclosure. Turn on the power of these power supplies to power-on the Enclosure. The “power” LED at the front panel will turn green.

If a power supply fails to function or a power supply was not turned on, the “” Power fail LED will turn red and an alarm will sound.

14. Cooling Fan module 3 ~ 4

2.3 Connecting to SAS HBA

The Enclosure supports SAS interface which provides fast 300MB data transfer rate using SAS phy. The package comes with one SAS cable. Attach one end of the SAS cable to the SAS IN port and the other end to the host adapter's external SAS connector or to the SAS Hub/Switch. (The host adapter is installed in your Host subsystem.)



Note:

For safety reasons, make sure the Disk Array and Host Computer are turned off when you plug-in the SAS cable.

2.4 Install Hard Drives

This section describes the physical locations of the hard drives supported by the Enclosure and gives instructions on installing a hard drive. The Enclosure supports hot-swapping allowing you to install or replace a hard drive while the Enclosure is running.

1. Pull out an empty disk tray. (You can install in any available slot.)
2. Take off the bracket before installing hard drive.

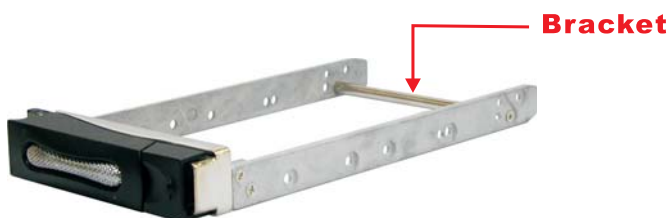

3. Place the hard drive in the disk tray.
4. Install the mounting screws on each side to secure the drive in the mobile rack.



Note:

Insert screws through the front sides of the mounting holes.

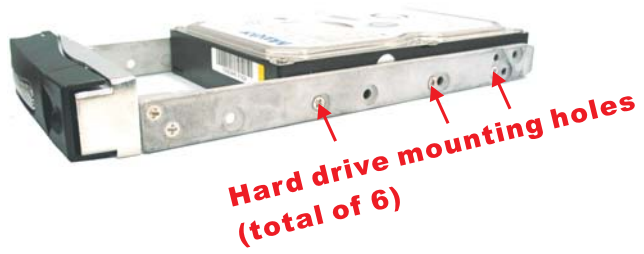

-
5. Slide the tray into a slot until it clicks into place. The HDD status LED will turn green on front panel.
 6. Press the lever in until you hear the latch click into place.
 7. If the HDD power LED did not turn green, check the hard drive is in good condition.
 8. If the hard drive is not being accessed, the HDD access LED will not illuminate. The LED blinks only when being accessed.

2.5 Powering-on the Enclosure

When you connect the enclosure to the Host computer, you should press the ON/OFF Power Supply Switch on both of the power supply units. It will turn the enclosure on and the Self-Test will be started automatically.

1. Plug in the power cord or power connector located at the rear of the enclosure.

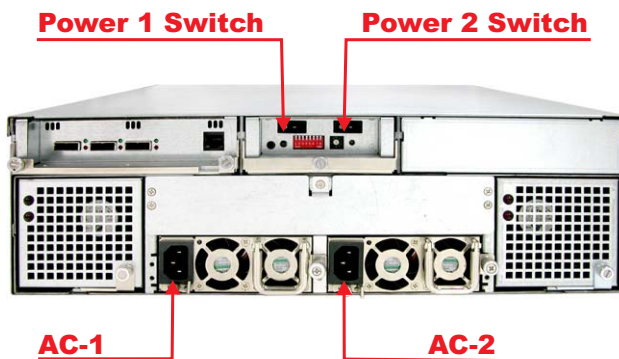

Note:

The enclosure is equipped with redundant PFC (power factor correction), Full Range power supplies. The enclosure will automatically selector voltage.

2. Turn on the power.
3. The “Power” LED on the front panel will turn green. After a few moments the LCD should display the following message:

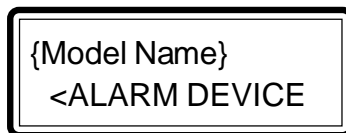

Chapter 3

Maintenance

This chapter describes more information about your Enclosure. The following items are describes in detail.

- ❖ *Environment Monitor & Configure*
- ❖ *Updating Firmware*
- ❖ *Hot Swap Components*

3.1 Environment Monitor & Configure

The enclosure is equipped with environmental monitoring unit which accurately monitors the internal environment of the enclosure such as the power supplies, temperature, voltage and cooling fans. This ensures high performance and reliability of the enclosure. When an abnormal condition occurs, the appropriate LED will turn red and an alarm will sound.

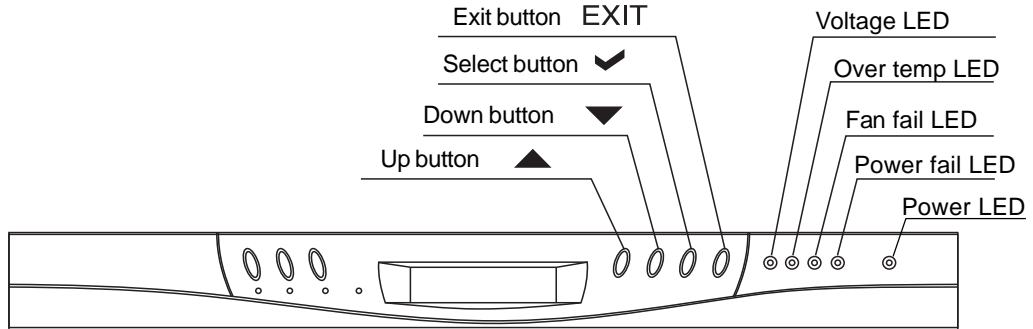

Function Key Definitions

Parts		Function
Up and Down arrow buttons	▲ ▼	Use the Up or Down arrow keys to go through the information on the LCD screen. This is also used to move between each menu when you configure the subsystem.
Select button	✓	This is used to enter the option you have selected.
Exit button	EXIT	Press this button to return to the previous menu.

Environment status

Parts		Function
Voltage warning LED	⚡	If the output DC voltage is over or under, an alarm will sound warning of voltage irregularity and this LED will turn red. 12V: over 12.8V / under 11.12V 5V: over 5.35V / under 4.63V 3.3V: over 3.53V / under 3.05V 1.2V: over 1.28V / under 1.12V
Over temp LED	🔥	If temperature irregularity in these systems occurs (HDD slot temperature over 60°C), this LED will turn red and an alarm will sound.
Fan fail LED	🌀	When a fan's rotation speed is lower than 500rpm, this LED will turn red and an alarm will sound.
Power fail LED	⊗	If a redundant power supply fails, this LED will turn red and an alarm will sound.
Power LED		Green LED indicates power is on.

Monitoring the RAID Environment

After power on the enclosure, the screen on the LCD panel will show the following message.



Press the “▼” button to enter the menu.

The following tree diagram is a summary of the various monitor functions that can be accessed through the LCD panel.

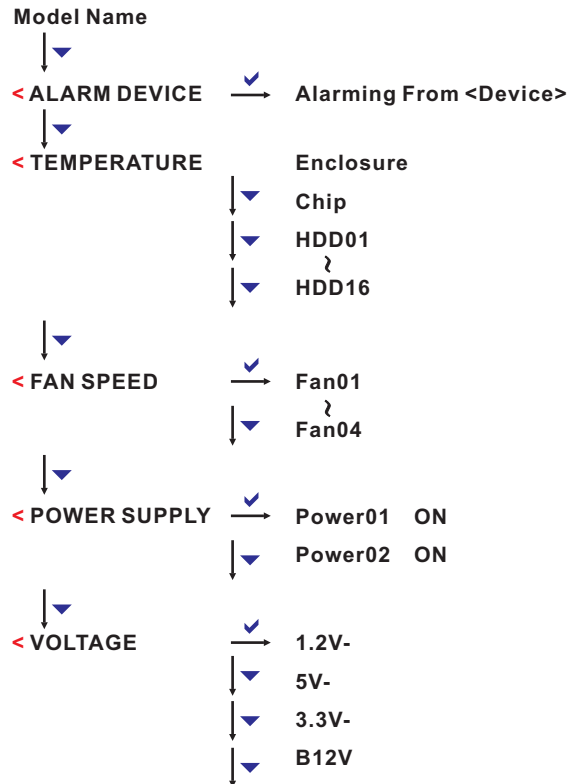

Press the “▼” button to enter the configure menu.

The enclosure has a setup configuration utility allows user to set temperature, LINK, FAN, Alarm and Password. The following tree diagram is a summary of the various setting functions that can be accessed through the LCD panel.

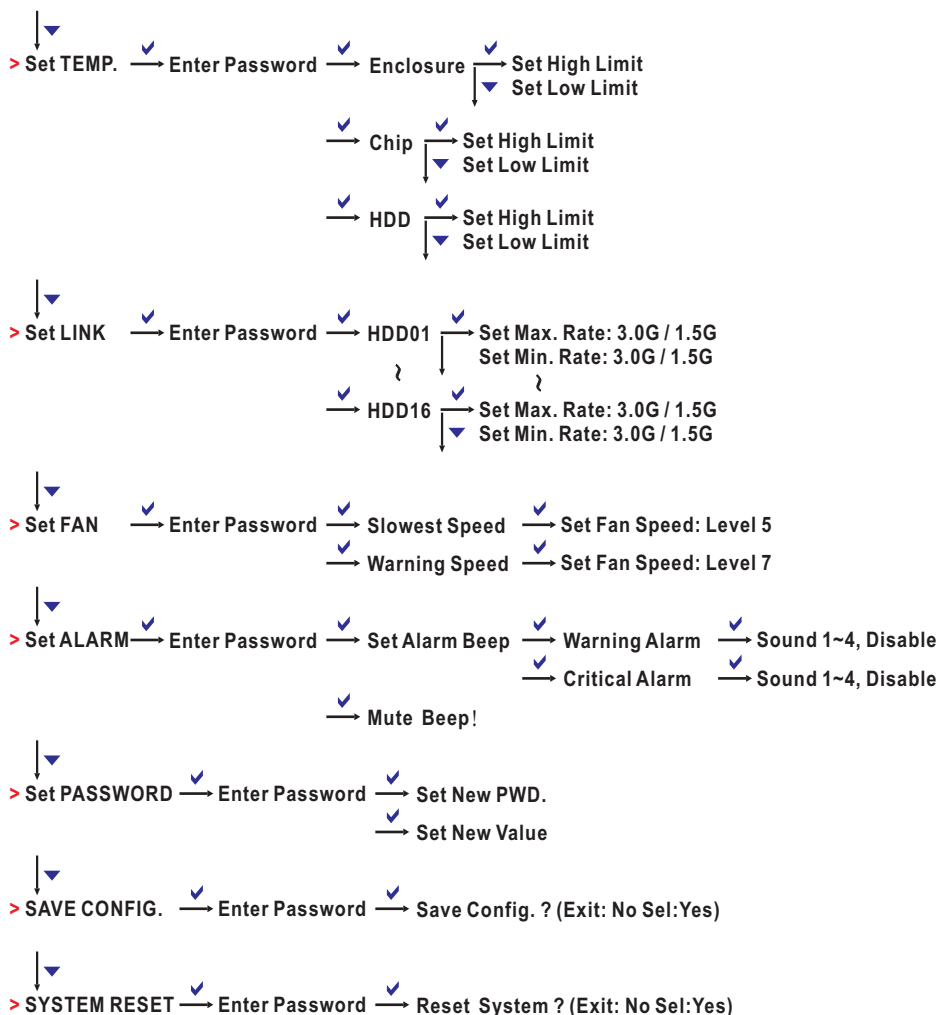

3.2 *Updating Firmware*

Upgrading Firmware through a Terminal

Connect a VT100 compatible terminal or a pc operating in an equivalent terminal emulation mode to the monitor port located at the rear of the enclosure.

The default setting of the monitor port is 115200 baud rate, 8 data bit, non-parity, 1 stop bit and no flow control.

The default password is 00000000.

1. CLI > er code (Rease old flash code)

Erase Flash Region...OK

2. CLI > fl code (Update flash code)

Wait to Receive File...CC (Wait 15 seconds)

(Then use XModem/1K protocol transmit file to update ROM, RegionST -
Store SES Element attribute in Flash)

OK: File Transmit & Pogram ROM!

3. CLI > xr (Restart)

3.3 Hot Swap Components

The enclosure supports hot-swappable disk trays, power supply modules and cooling fan unit. The following sections describe how to remove and install the “Hot-Swap” parts without interrupting the data access while the enclosure is on.

3.3.1 Replacing a disk

To replace a disk, perform the following steps (Refer to 2.4 Installing hard disks)

1. Open the tray lever by sliding the latch and wait for the drive to spin down.



2. Lift the lever to disengage the disk tray from the slot.
3. Gently pull the disk tray out of the slot.
4. Replace the HDD.
5. Slide the tray into a slot until it clicks into place. The HDD status LED will turn green on front panel.
6. Press the lever in until you hear the latch click into place.

3.3.2 Replacing a Power Supply

1. Unscrew the power supply.

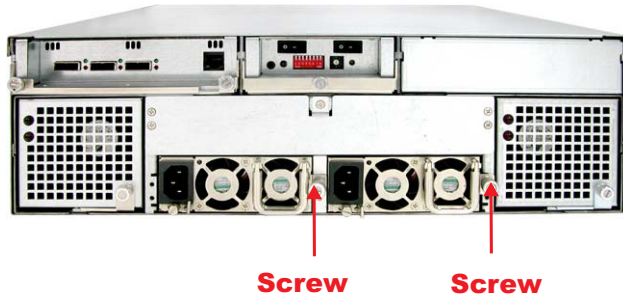

2. Use the handle to pull out the defective power supply.
3. Replace it with a 460W power supply.
4. Slide the new power supply in until it clicks into place.
5. Replace the screws you removed in step 1.

3.3.3 Replacing a Fan

1. Unscrew the fan holder.



2. The fans are attached to the fan holder. Remove the screws on the corners of the defective fan. Place the screws on a safe place as you will need them later when you install a new fan.



Note:

We recommend that you remove the fan holder from the enclosure. This allows easy installation and unlimited workspace when replacing the fan.

3. Install a new fan using the screws you removed in step 2.
4. Replace the fan holder.