

eSATA/USB/1394 to SATA II RAID Subsystem

User Manual

Revision 1.1

Table of Contents

Preface	5
Before You Begin.....	6
Safety Guidelines.....	6
Controller Configuration.....	6
Packaging, Shipment and Delivery.....	6
Unpacking the Subsystem.....	7
Chapter 1 Introduction	8
1.1 Key Features.....	9
1.2 Technical Specifications.....	10
1.3 Identifying Parts of the RAID Subsystem.....	11
1.3.1 Front View	11
1.3.1.1 Disk Trays.....	12
1.3.1.2 LCD Front Panel	13
1.3.2 Rear View.....	14
1.4 RAID Concepts	17
1.5 Array Definition.....	22
1.5.1 Raid Set.....	22
1.5.2 Volume Set	22
1.5.3 Easy to Use Features.....	23
1.5.3.1 Instant Availability/Background Initialization	23
1.5.3.2 Array Roaming.....	23
1.5.3.3 Online Capacity Expansion.....	23
1.5.3.4 Online RAID Level and Stripe Size Migration	24
1.5.4 High Availability	25
1.5.4.1 Creating Hot Spares	25
1.5.4.2 Hot-Swap Disk Drive Support.....	25
1.5.4.3 Hot-Swap Disk Rebuild	25
Chapter 2 Getting Started.....	26
2.1 Preparing the Subsystem and Powering On	26
2.2 Installing Hard Drives.....	26
Chapter 3 RAID Configuration	28

3.1	Configuring Through a Terminal	28
3.2	Configuring Using the LCD Panel	34
3.3	Menu Diagram	35
3.4	Web browser-based Remote RAID Management via R-Link Port	41
3.5	Quick Create	43
3.6	Raid Set Functions.....	44
3.6.1	Create Raid Set.....	44
3.6.2	Delete Raid Set.....	45
3.6.3	Expand Raid Set	46
3.6.4	Offline Raid Set	48
3.6.5	Activate Incomplete Raid Set	49
3.6.6	Create Hot Spare	51
3.6.7	Delete Hot Spare	51
3.6.8	Rescue Raid Set	52
3.7	Volume Set Function	53
3.7.1	Create Volume Set	53
3.7.2	Delete Volume Set	56
3.7.3	Modify Volume Set.....	57
3.7.3.1	Volume Expansion	58
3.7.4	Volume Set Migration	59
3.7.5	Check Volume Set.....	59
3.7.6	Stop Volume Set Check	61
3.8	Physical Drive	62
3.8.1	Create Pass-Through Disk	62
3.8.2	Modify Pass-Through Disk.....	63
3.8.3	Delete Pass-Through Disk	64
3.8.4	Identify Selected Drive	64
3.9	System Controls	65
3.9.1	System Configuration.....	65
3.9.2	iSCSI Configuration	68
3.9.3	EtherNet Config.....	69
3.9.4	Alert By Mail Config.....	71
3.9.5	SNMP Configuration	72
3.9.6	NTP Configuration.....	73
3.9.7	View Events/Mute Beeper	74
3.9.8	Generate Test Event	75
3.9.9	Clear Event Buffer	76
3.9.10	Modify Password.....	77
3.9.11	Upgrade Firmware	77
3.9.12	Shutdown Controller	78

3.9.13 Restart Controller.....	78
3.10 Information Menu.....	79
3.10.1 RaidSet Hierarchy.....	79
3.10.2 System Information.....	81
3.10.3 Hardware Monitor.....	82
3.11 Creating New Raid Set or Reconfiguring an Existing Raid Set.....	83
3.12 Upgrading the Firmware.....	84
Chapter 4 Appendix.....	90
4.1 Upgrading from Single Power Supply Mode to Redundant Mode (Optional).....	90

Preface

About this manual

This manual provides information regarding the hardware features, installation and configuration of the **RAID subsystem**. This document also describes how to use the storage management software. Information contained in the manual has been reviewed for accuracy, but not for product warranty because of the various environment/OS/settings. Information and specifications will be changed without further notice.

This manual uses section numbering for every topic being discussed for easy and convenient way of finding information in accordance with the user's needs. The following icons are being used for some details and information to be considered in going through with this manual:

**NOTES:**

These are notes that contain useful information and tips that the user must give attention to in going through with the subsystem operation.

**IMPORTANT!**

These are the important information that the user must remember.

**WARNING!**

These are the warnings that the user must follow to avoid unnecessary errors and bodily injury during hardware and software operation of the subsystem.

**CAUTION:**

These are the cautions that user must be aware to prevent damage to the equipment and its components.

Copyright

No part of this publication may be reproduced, stored in a retrieval system, or transmitted in any form or by any means, electronic, mechanical, photocopying, recording or otherwise, without prior written consent.

Trademarks

All products and trade names used in this document are trademarks or registered trademarks of their respective owners.

Changes

The material in this document is for information only and is subject to change without notice.

Before You Begin

Before going through with this manual, you should read and focus on the following safety guidelines. Notes about the subsystem's controller configuration and the product packaging and delivery are also included.

Safety Guidelines

To provide reasonable protection against any harm on the part of the user and to obtain maximum performance, user is advised to be aware of the following safety guidelines particularly in handling hardware components:

Upon receiving of the product:

- ❖ Place the product in its proper location.
- ❖ To avoid unnecessary dropping out, make sure that somebody is around for immediate assistance.
- ❖ It should be handled with care to avoid dropping that may cause damage to the product. Always use the correct lifting procedures.

Upon installing of the product:

- ❖ Ambient temperature is very important for the installation site. It must not exceed 30°C. Due to seasonal climate changes; regulate the installation site temperature making it not to exceed the allowed ambient temperature.
- ❖ Before plugging-in any power cords, cables and connectors, make sure that the power switches are turned off. Disconnect first any power connection if the power supply module is being removed from the enclosure.
- ❖ Outlets must be accessible to the equipment.
- ❖ All external connections should be made using shielded cables and as much as possible should not be performed by bare hand. Using anti-static hand gloves is recommended.
- ❖ In installing each component, secure all the mounting screws and locks. Make sure that all screws are fully tightened. Follow correctly all the listed procedures in this manual for reliable performance.

Controller Configuration

This RAID subsystem supports single controller configuration.

Packaging, Shipment and Delivery

- ❖ Before removing the subsystem from the shipping carton, you should visually inspect the physical condition of the shipping carton.
- ❖ Unpack and verify that the contents of the shipping carton are complete and in good condition.
- ❖ Exterior damage to the shipping carton may indicate that the contents of the carton are damaged.

If any damage is found, do not remove the components; contact the dealer where you purchased the subsystem for further instructions.

Unpacking the Subsystem

The package contains the following items:

	RAID Subsystem Unit
	Two(2) power cords
	One(1) RJ45 Ethernet cable
	One(1) external serial cable
	Two(2) USB Cables
	Two(2) external SATA cables
	Two(2) IEEE 1394 cables
	User Manual

NOTE: If any damage is found, contact the dealer or vendor for assistance.

Chapter 1 Introduction



The RAID Subsystem

Unsurpassed Value

- Most cost-effective SATA II RAID Subsystem

Application Flexibility

- Extends useful life by adapting to future IT requirements

Easy Installation, Upgrade & Maintenance

- Provide a fast and easy way to install and upgrade the storage. Simplified maintenance reduces ongoing IT labor costs

Exceptional Manageability

- Graphical User Interface (GUI) provides easy way for users to remotely manage and configure the storage
- Menu-driven LCD front panel makes it convenient for users to locally manage the storage

Green Power Concept

- Saves power by adopting the new technology "MAID" (Massive Arrays of Idle Disks) to spin-down idle drives

1.1 Key Features

Subsystem Features:

- USB 2.0 (480Mbps), 1394b (800Mbps), eSATA (3Gbps) host interface, iSCSI (AoE)
- Multiple Volume Sets for host access
- Supports Over 2TB Volume Set
- Supports hot spare and automatic hot rebuild
- Allows online capacity expansion within the enclosure
- Local audible event notification alarm
- Supports password protection
- Ethernet Port interface for remote event notification
- eSATA Support NCQ 32 Command, USB & iSCSI TCQ 256 Command
- Transparent data protection for all popular operating systems

RAID Management:

- Smart-function LCD panel
- Environmental monitoring unit
- Real time drive activity and status indicators
- Web-based GUI management utility

1.2 Technical Specifications

Feature	Specification
Form-factor	2U 19-inch rackmount chassis
RAID processor	400MHz storage I/O processor
RAID level	0, 1, 10, 3, 5, 6 and JBOD
Cache memory	256MB
No. of Channels (Host and Drive)	4 + 12
Host bus interface	USB2.0, 1394b & eSATA, R-Link (iSCSI)
Drive bus interface	SATA II (Up to 3.0Gbps)
Host Channel data transfer rate	Support up to 480Mbps (USB 2.0) Support up to 800Mbps (1394b) Support up to 3.0Gbps (SATA II) Support 10 / 100 / 1000 Mbps Ethernet
Hot-swap drive tray	Twelve (12) 1-inch trays
Power Supply Unit	400W x1(upgradeable) or 400W x2 Redundant power supplies w/PFC
Cooling fan	2
Password protection	Yes
Audible alarm	Yes
Failed drive indicators	Yes
Failed drive auto rebuild	Yes
Online consistency check	Yes
Online expansion	Yes
Array Roaming	Yes
Online RAID level/ stripe size migration	Yes
Instant availability and background initialization	Yes
Environment monitor	Yes
Auto spare support	Yes
Bad block auto-remapping	Yes
Remote management	Yes
MAID support	Yes
2TB Support	Windows OS which GPT supported (Windows XP/x64, 2003/SP1 or 64-bit, Vista,2008),Mac OS 10 or later, Linux kernel 2.6 or later
Power requirements	100V ~ 240V full range 8A ~ 4A, 47 ~ 63Hz
Relative Humidity	10% ~ 85% Non-condensing
Operating Temp	10°C ~ 40°C (50°F ~ 104°F)
Physical Dimensions	88(H) x 482(W) x 500(D)mm

1.3 Identifying Parts of the RAID Subsystem

The illustrations below identify the various parts of the subsystem.

1.3.1 Front View



1.3.1.1 Disk Trays



HDD Status Indicator

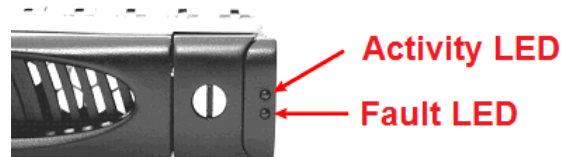

Part	Function
HDD Activity LED	This LED will blink blue when the hard drive is being accessed.
HDD Fault LED	Green LED indicates power is on and hard drive status is good for this slot. If hard drive is defective or failed, the LED is Red. LED is off when there is no hard drive.

Lock Indicator

Every Disk Tray is lockable and is fitted with a lock indicator to indicate whether or not the tray is locked into the chassis or not. Each tray is also fitted with an ergonomic handle for easy tray removal.

When the Lock Groove is horizontal, this indicates that the Disk Tray is locked. When the Lock Groove is vertical, then the Disk Tray is unlocked.

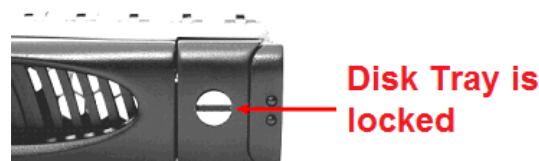
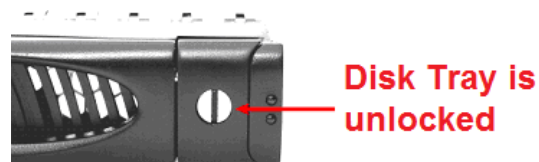



1.3.1.2 LCD Front Panel





Smart Function Front Panel

The smart LCD panel is an option to configure the RAID subsystem. If you are configuring the subsystem using the LCD panel, press the Select button to login and configure the RAID subsystem.

Parts	Function
Up and Down Arrow buttons 	Use the Up or Down arrow keys to go through the information on the LCD screen. This is also used to move between each menu when you configure the subsystem.
Select button 	This is used to enter the option you have selected.
Exit button EXIT	Press this button to return to the previous menu. NOTE: This button can also be used to reset the alarm beeper and turn off the Global fault LED.

Environment Status LEDs



Parts	Function
Power LED	Green LED indicates power is ON.
Global fault LED 	Red LED indicates a problem within the internal subsystem, such as fan fail/power supply fail/disk fault.
Activity LED 	This LED will blink blue when the Disk Array is busy or active.

1.3.2 Rear View

Redundant Power Supply

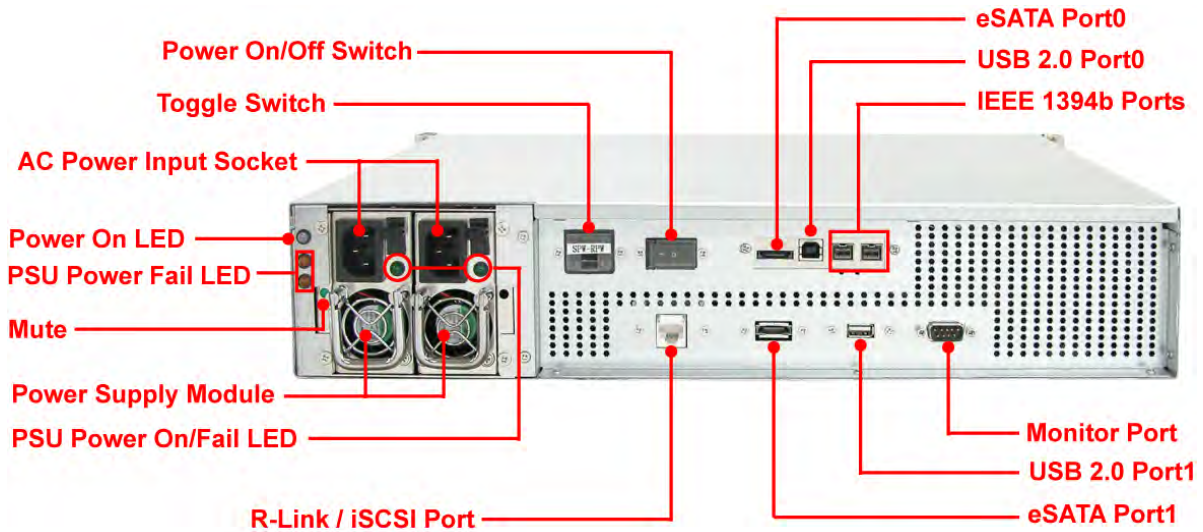

Single Power Supply

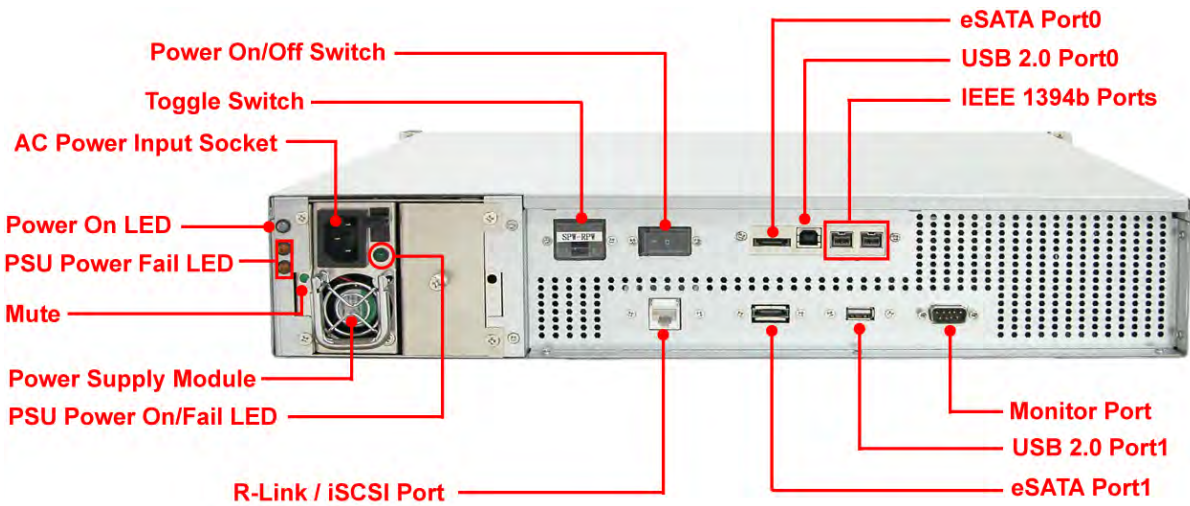

1. eSATA Port0 / USB 2.0 Port0 / IEEE 1394b Ports

The subsystem has external SATA II / USB 2.0 / IEEE 1394b host interface for connecting to the host system or server. Only one host interface can be used at a time.

2. eSATA Port1

The subsystem has another external SATA II host interface for connecting to the host system or server. This host interface is a separate channel and can be used simultaneously with the other eSATA II/USB 2.0/IEEE 1394b port.

3. USB 2.0 Port1

The subsystem has another USB 2.0 host interface for connecting to the host system or server. This host interface is a separate channel and can be used simultaneously with the other eSATA II/USB 2.0/IEEE 1394b port.



**eSATA0/USB/1394 use single channel
(same channel for all ports)**



**eSATA Port1 use another
channel (separate channel)**



**USB 2.0 Port1 use another
channel (separate channel)**



NOTE: When a Volume Set is created and mapped to "SATA" host channel, the Volume Set will be detected in the eSATA0/USB2.0/IEEE 1394b, or eSATA1. If another Volume Set is created and mapped to "USB" host channel, the Volume Set will be detected in the other USB port. Refer to 'Volume Set Function' → 'Create Volume Set' for more information.

4. R-Link / iSCSI Port: Remote Link through RJ-45 Ethernet for remote management

The subsystem is equipped with one 10/100/1000 RJ45 Ethernet LAN port. Use a web browser to remotely configure and monitor the RAID subsystem.

The R-Link Port is also used for accessing LUN via iSCSI (AoE) protocol.

5. Monitor Port

The subsystem is equipped with a serial monitor port allowing you to connect a PC or terminal for managing the RAID subsystem.

6. Power On/Off Switch

Use the Power On/Off Switch to power on or power off the RAID subsystem.

7. Toggle Switch - Use the toggle switch to change the power supply mode, from Single Mode to Redundant Mode, and vice versa.

8. Power Supply Unit

The subsystem has dual or single power supply unit.



NOTE: In order to maintain the system I/O performance, it is not recommended to access the storage from the different host interfaces at the same time.

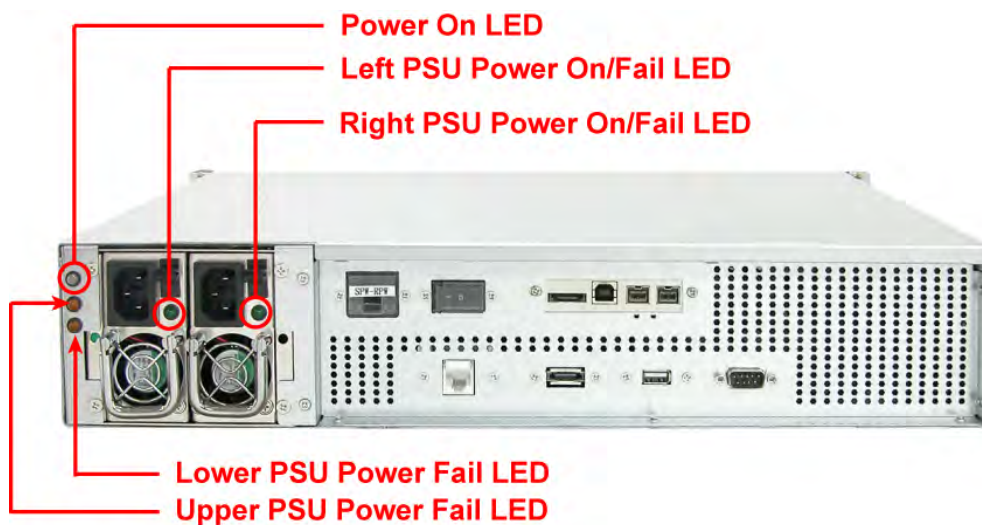

NOTE: After power on, when the Power On LED is green, the two PSU Power On/Fail LEDs are also green, and the PSU Power Fail LEDs are orange. When one Power Supply Module fails, the Power On LED will be blinking green and the PSU Power Fail LED will not light. The PSU Power On/Fail LED on left side is related to the upper PSU Power Fail LED, while the PSU Power On/Fail LED on right side is related to the lower PSU Power Fail LED.

1.4 RAID Concepts

RAID Fundamentals

The basic idea of RAID (Redundant Array of Independent Disks) is to combine multiple inexpensive disk drives into an array of disk drives to obtain performance, capacity and reliability that exceeds that of a single large drive. The array of drives appears to the host computer as a single logical drive.

Five types of array architectures, RAID 1 through RAID 5, were originally defined; each provides disk fault-tolerance with different compromises in features and performance. In addition to these five redundant array architectures, it has become popular to refer to a non-redundant array of disk drives as a RAID 0 arrays.

Disk Striping

Fundamental to RAID technology is striping. This is a method of combining multiple drives into one logical storage unit. Striping partitions the storage space of each drive into stripes, which can be as small as one sector (512 bytes) or as large as several megabytes. These stripes are then interleaved in a rotating sequence, so that the combined space is composed alternately of stripes from each drive. The specific type of operating environment determines whether large or small stripes should be used.

Most operating systems today support concurrent disk I/O operations across multiple drives. However, in order to maximize throughput for the disk subsystem, the I/O load must be balanced across all the drives so that each drive can be kept busy as much as possible. In a multiple drive system without striping, the disk I/O load is never perfectly balanced. Some drives will contain data files that are frequently accessed and some drives will rarely be accessed.

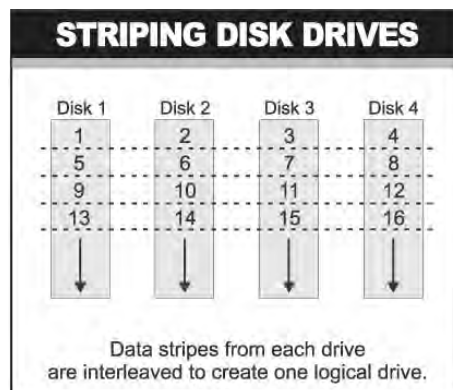

By striping the drives in the array with stripes large enough so that each record falls entirely within one stripe, most records can be evenly distributed across all drives. This keeps all drives in the array busy during heavy load situations. This situation allows all drives to work concurrently on different I/O operations, and thus maximize the number of simultaneous I/O operations that can be performed by the array.

Definition of RAID Levels

RAID 0 is typically defined as a group of striped disk drives without parity or data redundancy. RAID 0 arrays can be configured with large stripes for multi-user environments or small stripes for single-user systems that access long sequential records. RAID 0 arrays deliver the best data storage efficiency and performance of any array type. The disadvantage is that if one drive in a RAID 0 array fails, the entire array fails.

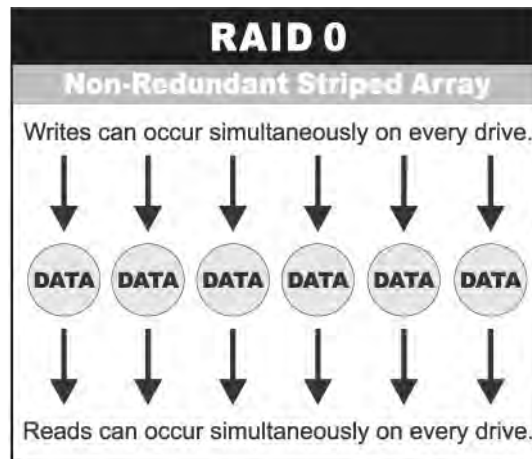

RAID 1, also known as disk mirroring, is simply a pair of disk drives that store duplicate data but appear to the computer as a single drive. Although striping is not used within a single mirrored drive pair, multiple RAID 1 arrays can be striped together to create a single large array consisting of pairs of mirrored drives. All writes must go to both drives of a mirrored pair so that the information on the drives is kept identical. However, each individual drive can perform simultaneous, independent read operations. Mirroring thus doubles the read performance of a single non-mirrored drive and while the write performance is unchanged. RAID 1 delivers the best performance of any redundant array type. In addition, there is less performance degradation during drive failure than in RAID 5 arrays.

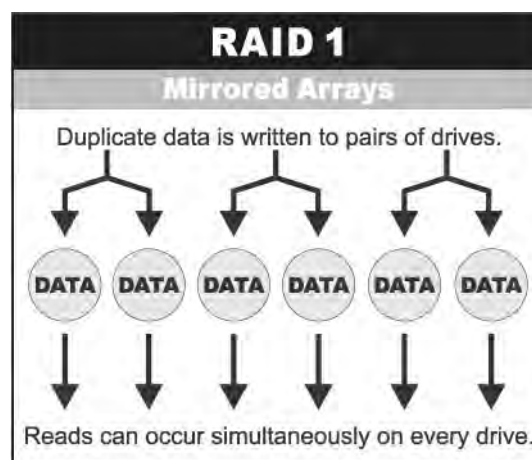

RAID 3 sector-stripes data across groups of drives, but one drive in the group is dedicated to storing parity information. RAID 3 relies on the embedded ECC in each sector for error detection. In the case of drive failure, data recovery is accomplished by calculating the exclusive OR (XOR) of the information recorded on the remaining drives. Records typically span all drives, which optimizes the disk transfer rate. Because each I/O request accesses every drive in the array, RAID 3 arrays can satisfy only one I/O request at a time. RAID 3 delivers the best performance for single-user, single-tasking environments with long records. Synchronized-spindle drives are required for RAID 3 arrays in order to avoid performance degradation with short records. RAID 5 arrays with small stripes can yield similar performance to RAID 3 arrays.

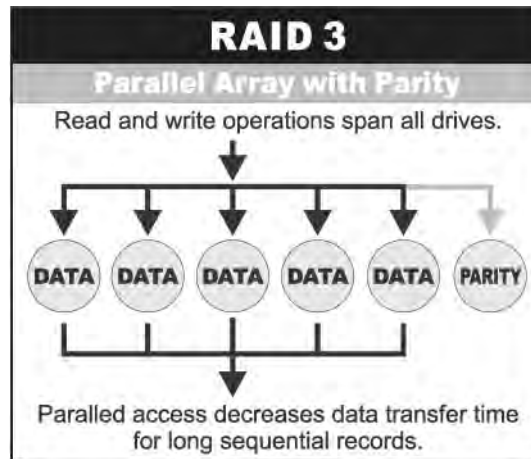

Under **RAID 5** parity information is distributed across all the drives. Since there is no dedicated parity drive, all drives contain data and read operations can be overlapped on every drive in the array. Write operations will typically access one data drive and one parity drive. However, because different records store their parity on different drives, write operations can usually be overlapped.

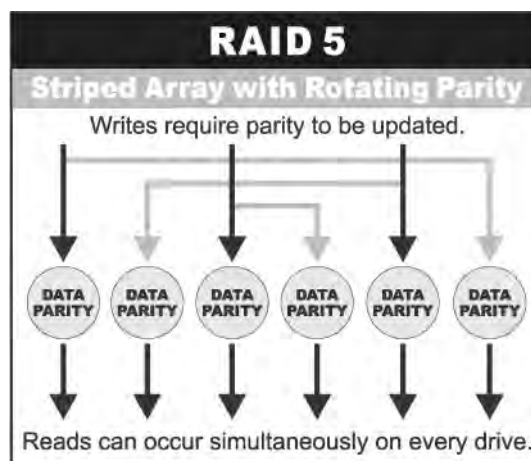

Dual-level RAID achieves a balance between the increased data availability inherent in RAID 1 and the increased read performance inherent in disk striping (RAID 0). This array is sometimes referred to as RAID 10.

RAID 6 is similar to RAID 5 in that data protection is achieved by writing parity information to the physical drives in the array. With RAID 6, however, *two* sets of parity data are used. These two sets are different, and each set occupies a capacity equivalent to that of one of the constituent drives. The main advantage of RAID 6 is High data availability – any two drives can fail without loss of critical data.

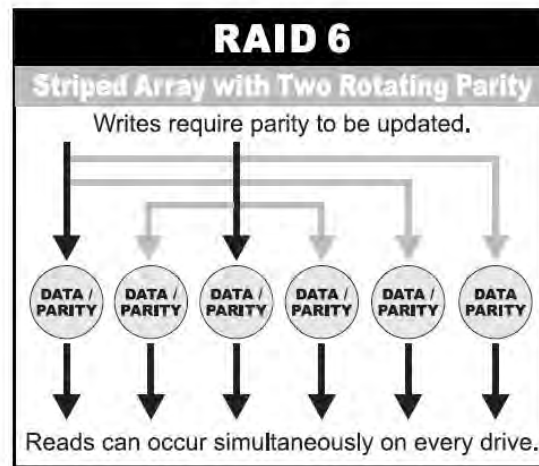

In summary:

- RAID 0 is the fastest and most efficient array type but offers no fault-tolerance. RAID 0 requires a minimum of one drive.
- RAID 1 is the best choice for performance-critical, fault-tolerant environments. RAID 1 is the only choice for fault-tolerance if no more than two drives are used.
- RAID 3 can be used to speed up data transfer and provide fault-tolerance in single-user environments that access long sequential records. However, RAID 3 does not allow overlapping of multiple I/O operations and requires synchronized-spindle drives to avoid performance degradation with short records. RAID 5 with a small stripe size offers similar performance.
- RAID 5 combines efficient, fault-tolerant data storage with good performance characteristics. However, write performance and performance during drive failure is slower than with RAID 1. Rebuild operations also require more time than with RAID 1 because parity information is also reconstructed. At least three drives are required for RAID 5 arrays.
- RAID 6 is essentially an extension of RAID level 5 which allows for additional fault tolerance by using a second independent distributed parity scheme (two-dimensional parity). Data is striped on a block level across a set of drives, just like in RAID 5, and a second set of parity is calculated and written across all the drives; RAID 6 provides for an extremely high data fault tolerance and can sustain multiple simultaneous drive failures. It is a perfect solution for mission critical applications.

RAID Management

The subsystem can implement several different levels of RAID technology. RAID levels supported by the subsystem are shown below.

RAID Level	Description	Min. Drives
0	Block striping is provide, which yields higher performance than with individual drives. There is no redundancy.	1
1	Drives are paired and mirrored. All data is 100% duplicated on an equivalent drive. Fully redundant.	2
3	Data is striped across several physical drives. Parity protection is used for data redundancy.	3
5	Data is striped across several physical drives. Parity protection is used for data redundancy.	3
10 (1E)	Combination of RAID levels 1 and 0. This level provides redundancy through mirroring and striping. RAID 10 requires the use of an <u>even number</u> of disk drives to achieve data protection, while RAID 1E (Enhanced Mirroring) uses an <u>odd number</u> of drives.	4 (3)
6	Data is striped across several physical drives. Parity protection is used for data redundancy. Requires N+2 drives to implement because of two-dimensional parity scheme	4

1.5 Array Definition

1.5.1 Raid Set

A Raid Set is a group of disk drives containing one or more logical volumes called Volume Sets. It is not possible to have multiple Raid Sets on the same disk drives.

A Volume Set must be created either on an existing Raid Set or on a group of available individual disk drives (disk drives that are not yet a part of a Raid Set). If there are existing Raid Sets with available raw capacity, new Volume Set can be created. New Volume Set can also be created on an existing Raid Set without free raw capacity by expanding the Raid Set using available disk drive(s) which is/are not yet Raid Set member. If disk drives of different capacity are grouped together in a Raid Set, then the capacity of the smallest disk will become the effective capacity of all the disks in the Raid Set.

1.5.2 Volume Set

A Volume Set is seen by the host system as a single logical device. It is organized in a RAID level with one or more physical disks. RAID level refers to the level of data performance and protection of a Volume Set. A Volume Set capacity can consume all or a portion of the raw capacity available in a Raid Set. Multiple Volume Sets can exist on a group of disks in a Raid Set. Additional Volume Sets created in a specified Raid Set will reside on all the physical disks in the Raid Set. Thus each Volume Set on the Raid Set will have its data spread evenly across all the disks in the Raid Set. Volume Sets of different RAID levels may coexist on the same Raid Set.

In the illustration below, Volume 1 can be assigned RAID level 5 while Volume 0 might be assigned RAID level 10.

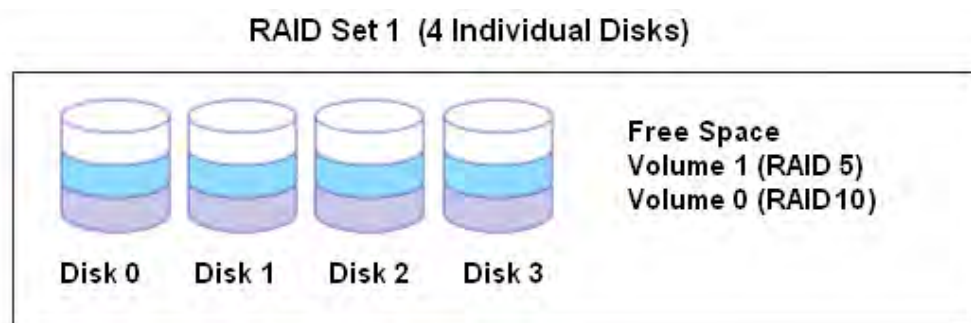

1.5.3 Easy to Use Features

1.5.3.1 Instant Availability/Background Initialization

RAID 0 Volume Set can be used immediately after the creation. But the RAID 1, RAID 10, RAID 3, 5 and 6 Volume Sets must be initialized to generate the stripes and/or parity. In the Background Mode initialization, the initialization proceeds as a background task, and the Volume Set is fully accessible for system reads and writes. The operating system can have instant access to the newly created Volume Sets without waiting for the initialization to be completed. One disadvantage of this is that the initialization process takes longer time. In Foreground Mode initialization, the initialization process is faster but must be completed first before the Volume Set is ready for system access.

1.5.3.2 Array Roaming

The RAID subsystem stores configuration information both in NVRAM and on the disk drives. This protects the configuration settings in the case of a disk drive or controller failure. Array roaming allows the administrator the ability to move a complete Raid Set to another system without losing RAID configuration and data on that Raid Set. If a RAID enclosure fails to work, the Raid Set disk drives can be moved to another enclosure and inserted in any order.

1.5.3.3 Online Capacity Expansion

Online Capacity Expansion makes it possible to add one or more physical drives to a Raid Set, while the server is in operation, eliminating the need to backup and restore after reconfiguring the Raid Set. When disks are added to a Raid Set, unused capacity is added at the end of the Raid Set. Data on the existing Volume Sets residing on that Raid Set is redistributed evenly across all the disks. A contiguous block of unused capacity is made available on the Raid Set. The unused capacity can be used to create additional Volume Set. The expansion process is illustrated as follows.

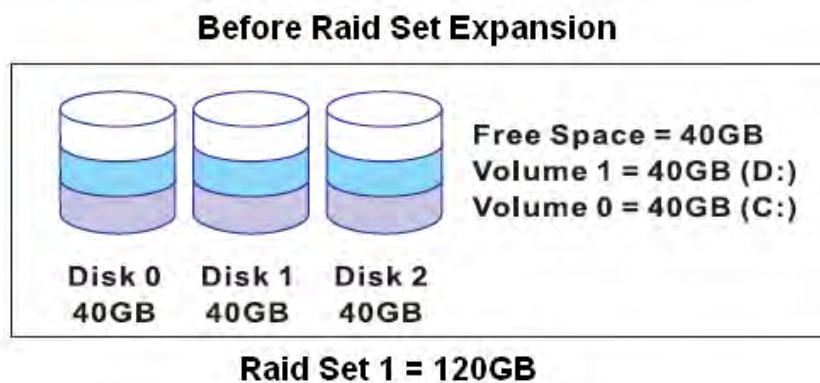

The RAID subsystem controller redistributes the original Volume Set over the original and newly added disks, using the same RAID level configuration. The unused capacity on the expanded Raid Set can then be used to create additional Volume Sets, with different RAID level settings as needed by user.

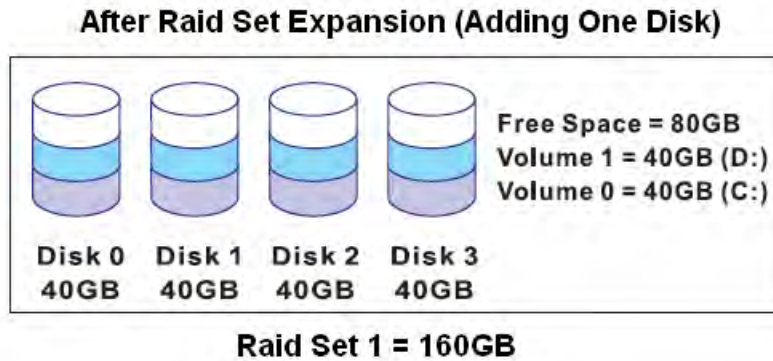

1.5.3.4 Online RAID Level and Stripe Size Migration

User can do migration on both the RAID level and Stripe Size of an existing Volume Set while the server is online and the Volume Set is in use. Online RAID level/stripe size migration can prove helpful during performance tuning activities as well as in the event that additional physical disk(s) is/are added to the RAID subsystem. For example, in a system using two drives in RAID level 1, you could add capacity and retain fault tolerance by adding one drive. With the addition of third disk, you have the option of adding this disk to your existing RAID logical drive and migrating from RAID level 1 to 5. The result would be parity fault tolerance and doubled available capacity without taking the system off.

1.5.4 High Availability

1.5.4.1 Creating Hot Spares

A hot spare drive is an unused online available drive, which is ready to replace a failed disk drive. In a RAID level 1, 10, 3, 5 or 6 Raid Set, any unused online available drive installed but not belonging to a Raid Set can be defined as a hot spare drive. Hot spares permit you to replace failed drives without powering down the system. When the RAID subsystem detects a drive failure, the system will do automatic and transparent rebuild using the hot spare drives. The Raid Set will be reconfigured and rebuilt in the background while the RAID subsystem continues to handle system request. During the automatic rebuild process, system activity will continue as normal. However, system performance and fault tolerance will be affected.



IMPORTANT: The hot spare must have at least the same or more capacity than the drive it replaces.

1.5.4.2 Hot-Swap Disk Drive Support

The RAID subsystem has built-in protection circuit to support the replacement of SATA II hard disk drives without having to shut down or reboot the system. The RAID controller and backplane delivers “hot swappable” fault-tolerant RAID solution at a price much less than the cost of conventional SCSI hard disk RAID subsystems. This feature is provided in the RAID subsystem for advance fault tolerant RAID protection and “online” drive replacement.

1.5.4.3 Hot-Swap Disk Rebuild

The Hot-Swap feature can be used to rebuild Raid Sets with data redundancy such as RAID level 1, 10, 3 and 5. If a hot spare is not available, the failed disk drive must be replaced with a new disk drive so that the data on the failed drive can be rebuilt. If a hot spare is available, the rebuild starts automatically when a drive fails. The RAID subsystem automatically and transparently rebuilds failed drives in the background with user-definable rebuild rates. The RAID subsystem will automatically continue the rebuild process if the subsystem is shut down or powered off abnormally during a reconstruction process.

Chapter 2 Getting Started

2.1 Preparing the Subsystem and Powering On

Here are the basic steps to prepare the RAID subsystem for use.

1. Attach one end of network cable to the R-Link port and connect the other end to your network hub/switch. Or as alternative for configuration, you may connect the serial cable to the Monitor port and to the serial port of your PC/host/server.
2. Connect the eSATA cable/USB cable/IEEE 1394 cable to the eSATA/USB/1394 port of the RAID subsystem and to the host system or server that will use the storage.
3. Connect the power cord to the AC input socket. Plug the other end of power cord to the power source.
4. Press the Power On/Off switch at the rear of the subsystem.

2.2 Installing Hard Drives

This section describes the physical locations of the hard drives supported by the subsystem and gives instructions on installing a hard drive. The subsystem supports hot-swapping allowing you to install or replace a hard drive while the subsystem is running.

Each Drive Carrier has a locking mechanism. When the Lock Groove, which is located in carrier open button, is horizontal, the Drive Carrier is locked. When the Lock Groove is vertical, the Drive Carrier is unlocked. Lock and unlock the Drive Carriers by using a flat-head screwdriver.

- a. Make sure the lock indicator is in unlocked position. To pull out a disk tray, press the carrier open button.



- b. Pull out an empty disk tray. Pull the lever handle outwards to remove the carrier from the enclosure.

- c. Place the hard drive in the disk tray.



- d. Install the mounting screws on the bottom part to secure the drive in the disk tray.

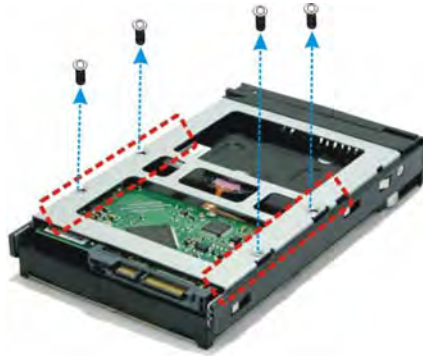

- e. Slide the tray into a slot.

- f. Close the lever handle until you hear the latch click into place.

Chapter 3 RAID Configuration

The subsystem has a built-in setup utility containing important information about the configuration as well as settings for various optional functions in the subsystem. This chapter explains how to use and make changes to the setup utility.

Configuration Methods

There are three methods of configuring the subsystem. You may configure through the following methods:

- VT100 terminal connected through the controller's serial port
- Front panel touch-control keypad
- Web browser-based Remote RAID management via the R-Link Ethernet port



IMPORTANT! The subsystem allows you to access the utility using only one method at a time. You cannot use more than one method at the same time.

3.1 Configuring Through a Terminal

Configuring through a terminal allows you to use the same configuration options and functions that are available from the LCD panel. To start-up:

1. Connect a VT100 compatible terminal or a PC operating in an equivalent terminal emulation mode to the monitor port located at the rear of the subsystem.



NOTE: You may connect a terminal while the subsystem's power is on.

2. Power-on the terminal.
3. Run the VT100 program or an equivalent terminal program.

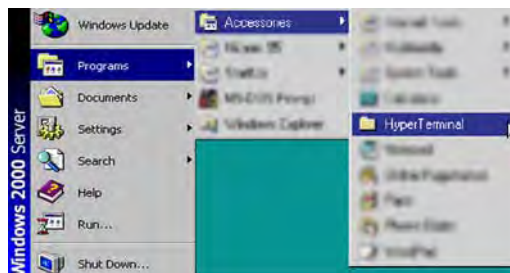



4. The default setting of the monitor port is 115200 baud rate, 8 data bit, non-parity, 1 stop bit and no flow control.

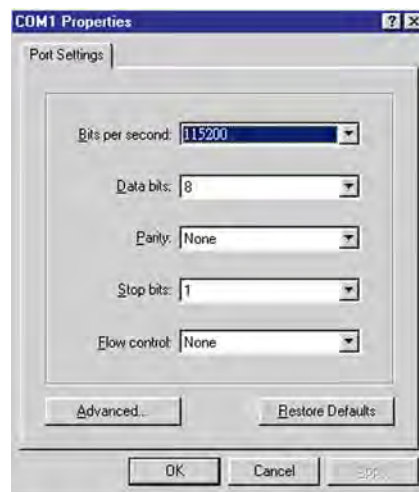

5. Click  disconnect button.

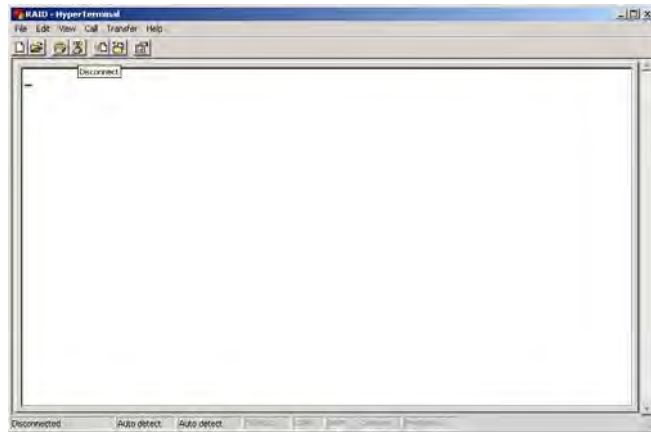

6. Open the File menu, and then open Properties.

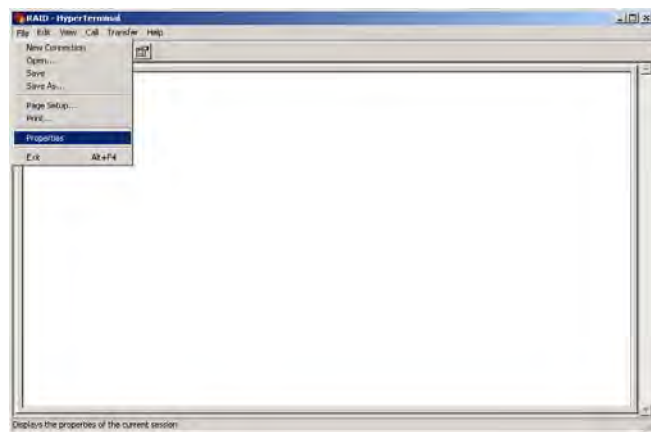

7. Open the Settings Tab.

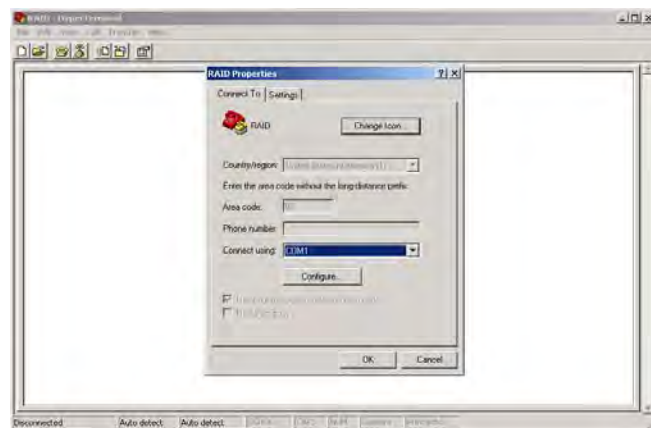

8. Configure the settings are follows:
 - “Function, arrow and ctrl keys act as”: Terminal Keys
 - “Backspace key sends”: Ctrl + H
 - “Emulation”: VT100
 - “Telnet terminal ID”: VT100
 - “Back scroll buffer lines”: 500
 Click OK.

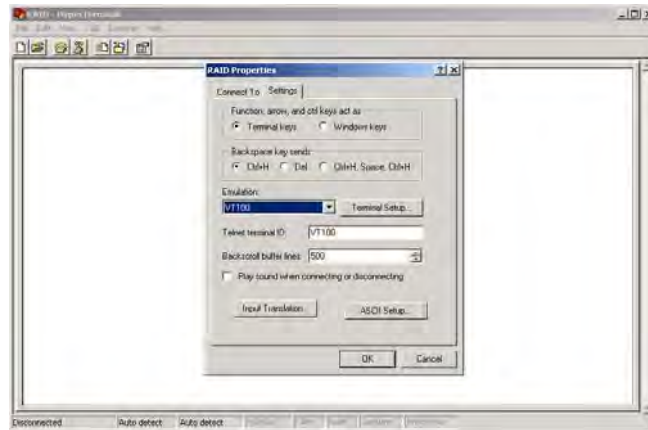

9. Now, the VT100 is ready to use. After you have finished the VT100 Terminal setup, you may press the “X” key (in your Terminal) to link the RAID subsystem and Terminal together. Press “X” key to display the disk array Monitor Utility screen on your VT100 Terminal.
10. The Main Menu will appear.



Keyboard Function Key Definitions

- “A” key - to move to the line above
- “Z” key - to move to the next line
- “Enter” key - Submit selection function
- “ESC” key - Return to previous screen
- “L” key - Line draw
- “X” key – Redraw

Main Menu

The main menu shows all available functions that user can execute by selecting the appropriate menu or option.



NOTE: The password option allows user to set or clear the RAID subsystem's password protection feature. Once the password has been set, the user can only monitor and configure the RAID subsystem by providing the correct password. The password is used to protect the RAID subsystem from unauthorized access. The controller will check the password only when entering the Main menu from the initial screen. The RAID subsystem will automatically go back to the initial screen when it is inactive or has not received any command in twenty seconds. The RAID subsystem's factory default password is set to 00000000.

VT100 terminal configuration Utility Main Menu Options

Select a menu option and the related information or submenu items are displayed. The submenus for each item are shown in Section 3.3. The configuration utility menu options are:

Option	Description
Quick Volume And Raid Set Setup	Create a RAID configuration which consists of all physical disks installed
Raid Set Functions	Create a customized Raid Set
Volume Set Functions	Create a customized Volume Set
Physical Drive Functions	View individual disk information
Raid System Functions	Setting the Raid system configurations
Ethernet Configuration	Setting the Ethernet configurations
Views System Events	Display all system events
Clear Event Buffer	Clear all event buffer information
Hardware Monitor	Show all system environment status
System Information	View the controller information



3.2 Configuring Using the LCD Panel

The LCD front panel function keys are the primary user interface for the RAID subsystem. Except for the "Firmware update", all configurations can be performed through this interface. The LCD provides a system of screens with areas for information, status indication, or menus. The LCD screen displays up to two lines of menu items or other information at a time. The RAID subsystem's factory default password is set to **00000000**.

Front Panel Function Keys



The four function keys on the front panel perform the following functions:

Parts	Function
Up and Down Arrow buttons 	Use the Up or Down arrow keys to go through the information on the LCD screen. This is also used to move between each menu when you configure the subsystem.
Select button 	This is used to enter the option you have selected.
Exit button EXIT	Press this button to return to the previous menu.

3.3 Menu Diagram

The following tree diagram is a summary of the various configurations and setting functions that can be accessed through the terminal monitor. Also, almost the same menu can be accessed through the LCD panel.

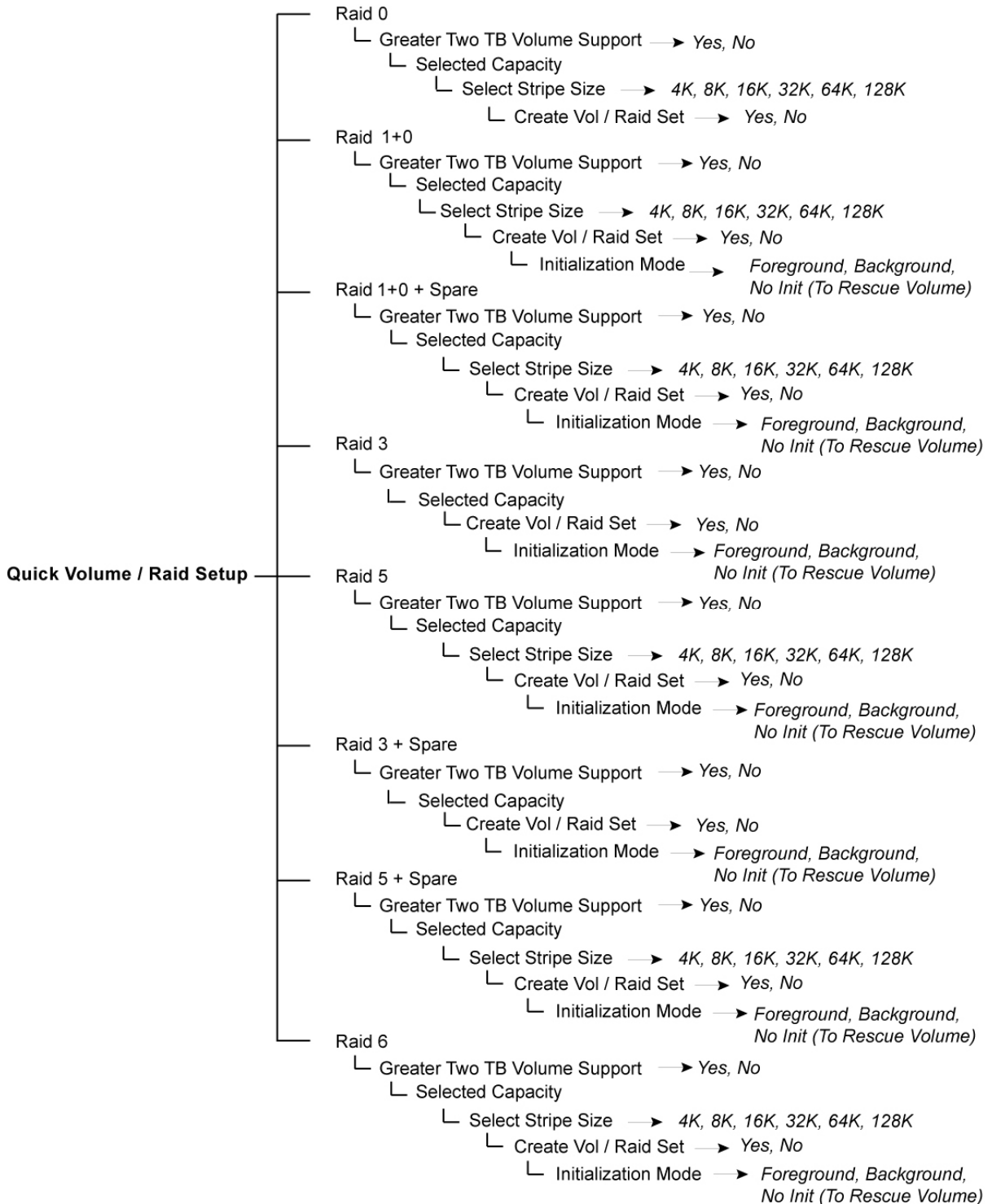

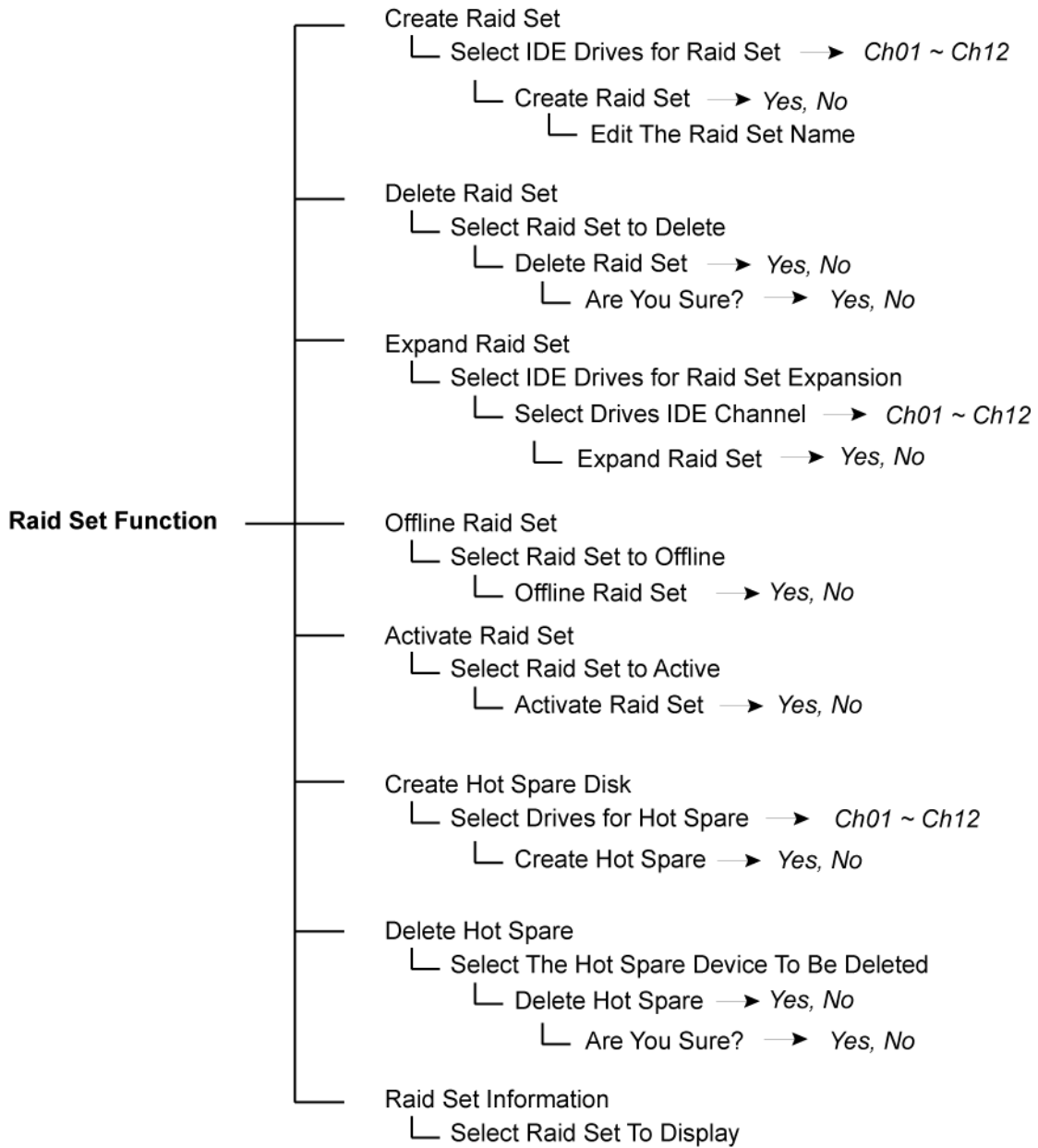

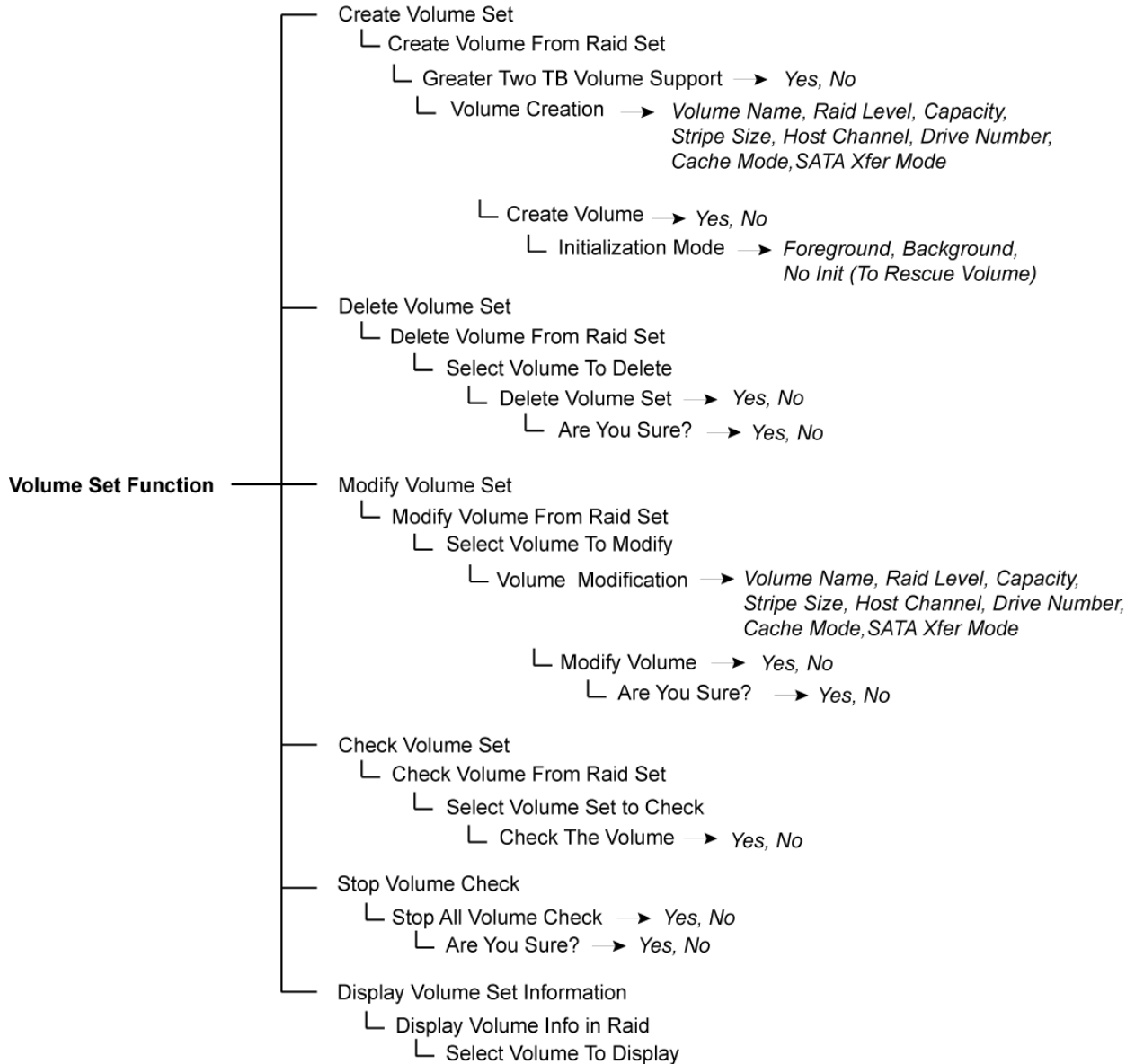

NOTE: Some SATA cards/controllers cannot detect over 2TB Volume.

When a Volume Set is mapped to "SATA" host channel, the Volume Set will be detected in the eSATA/USB/1394 port (4 ports but single channel). Only one port can be used at a time. If another Volume Set is mapped to "USB" host channel, the Volume Set will be detected in the other USB port (other channel).

The Volume Set size can be over 2 Terabytes. Use OS: Windows 2003 SP1 or later, Windows Vista, Mac OS 10 or later, and Linux kernel 2.6 or later.

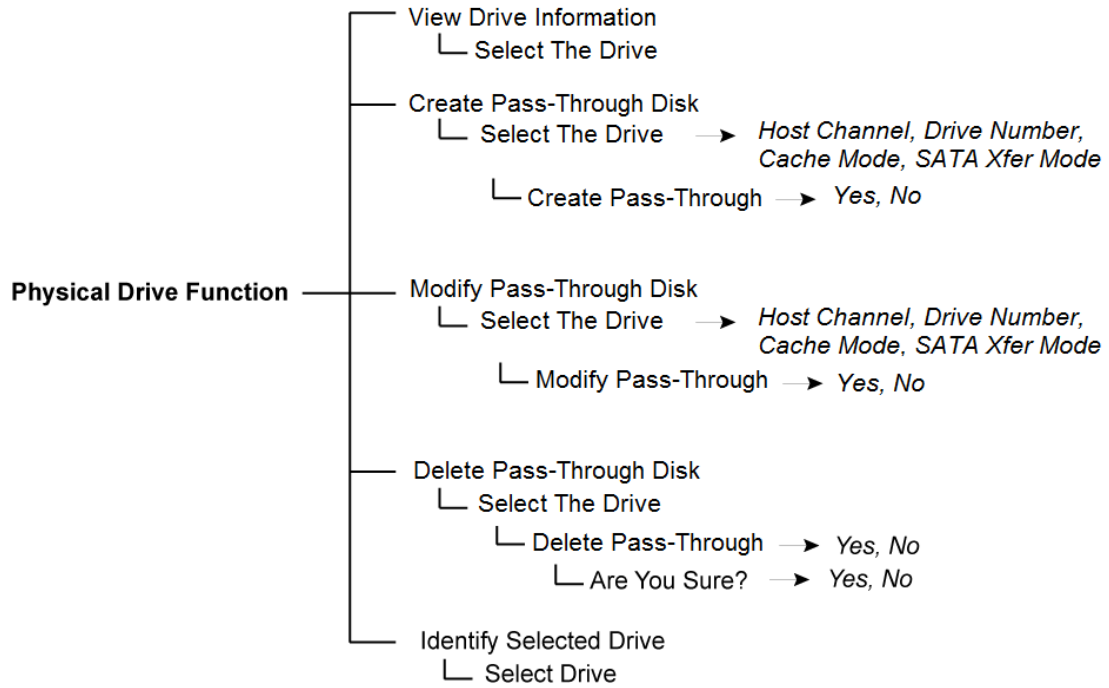

Raid System Function

- Mute The Alert Beeper → Yes, No
- Alert Beeper Setting → Disabled, Enabled
 - └ Save The Settings → Yes, No
- Change Password
 - └ Enter New Password
 - └ Re-Enter Password
 - └ Save The Password → Yes, No
- JBOD / RAID Function
 - └ RAID, JBOD
 - └ Configured AS JBOD? → Yes, No
 - └ Are You Sure? → Yes, No
- Background Task Priority → UltraLow(5%), Low(20%)
Medium(50%), High(80%)
 - └ Save The Settings → Yes, No
- Maximum SATA Mode Supported → SATA150, SATA150+NCQ
SATA300, SATA300+NCQ
- Host NCQ Mode Setting → Disabled, ESB2/MACPro/SiliconImage,
ICH, Marvell 6145, nVidia
 - └ Save The Settings → Yes, No
- HDD Read Ahead Cache → Enable, Disable Maxtor, Disable
 - └ Save The Settings → Yes, No
- Volume Data Read Ahead → Normal, Aggressive, Conservative, Disabled
 - └ Save The Settings → Yes, No
- Stagger Power On → 0.4, 0.7, 1.0, 1.5, 2.0, 2.5, 3.0,
3.5, 4.0, 4.5, 5.0, 5.5, 6.0
 - └ Save The Settings → Yes, No
- Spin Down Idle HDD → Disabled, 1, 3, 5, 10, 15,
20, 30, 40, 60
 - └ Save The Settings → Yes, No
- Empty HDD Slot LED Control → ON / OFF
 - └ Save The Settings → Yes, No
- HDD Smart Status Polling → Disabled, Enabled
 - └ Save The Settings → Yes, No
- Auto Activate Raid Set → Disabled, Enabled
 - └ Save The Settings → Yes, No
- Capacity Truncation → To Multiples of 10G,
To Multiples of 1G, Disabled
- Terminal Port Configuration
 - └ Baud Rate → 1200, 2400, 4800, 9600, 19200,
38400, 57600, 115200
 - └ Save The Settings → Yes, No
 - └ Stop Bits → 1 bit, 2 bits
 - └ Save The Settings → Yes, No
- Update Firmware
- Shutdown Controller
 - └ Confirm Shutdown → Yes, No
 - └ Are You Sure → Yes, No
- Restart Controller
 - └ Confirm Reset → Yes, No
 - └ Are You Sure → Yes, No

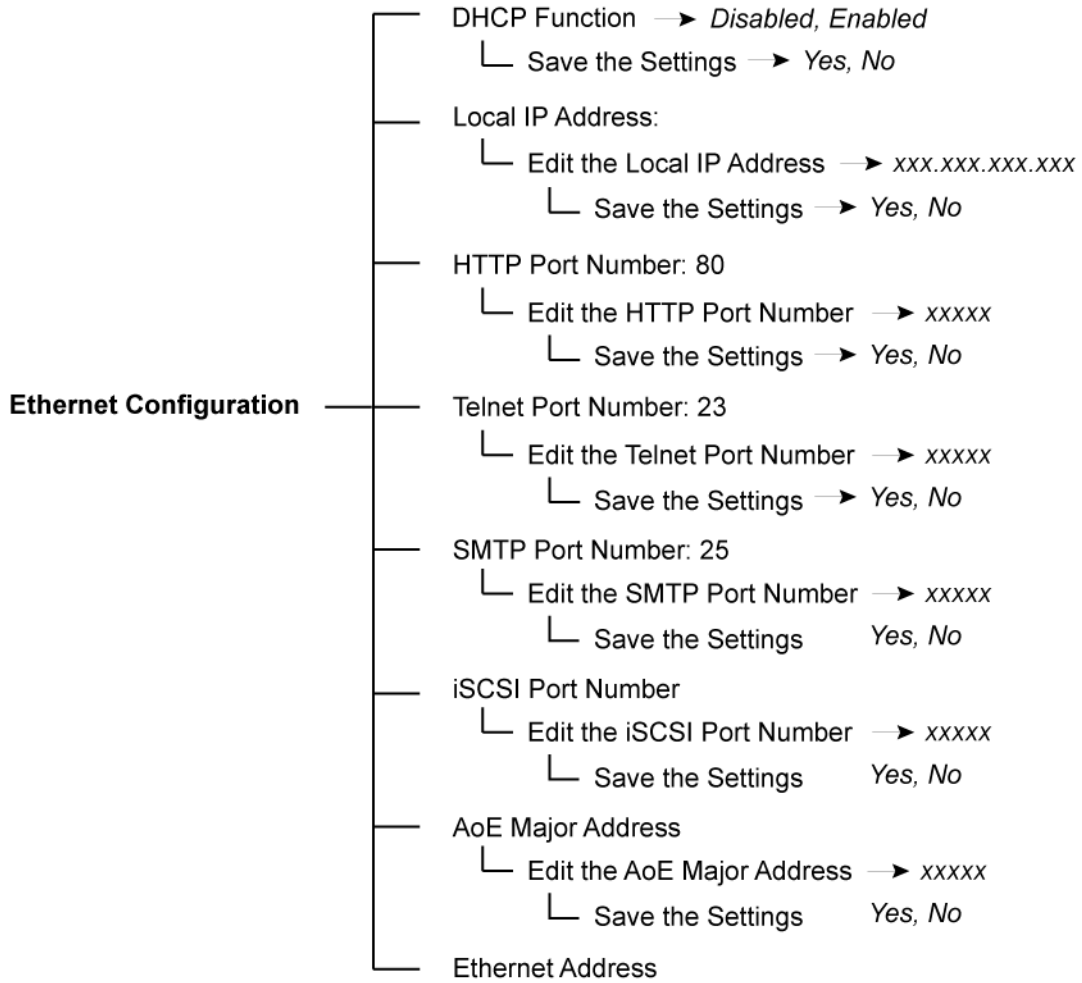

- View System Events** — Show System Events
- Clear Event Buffers** — Clear Event Buffer → *Yes, No*
- Hardware Monitor** — The Hardware Monitor Information
- System Information** — The System Information

3.4 Web browser-based Remote RAID Management via R-Link Port

The RAID subsystem can be configured with RAID Manager, a web browser-based application. The RAID Manager can be used to manage all the RAID function.

To configure the RAID subsystem from a remote machine, you need to know its IP Address. To open RAID Manager, launch your web browser in the remote machine and enter in the address bar: <http://<IP-Address>>.



IMPORTANT! The default IP address of R-Link Port is 192.168.1.100, and subnet mask is 255.255.255.0. DHCP client function is also enabled by default. You can reconfigure the IP Address or disable the DHCP client function through the LCD front panel or terminal "Ethernet Configuration" menu.



NOTE: If DHCP client function is enabled but a DHCP server is unavailable and the IP address is changed, a Controller Restart is necessary. If the DHCP client function is disabled and the IP address is changed, Controller Restart is not needed.

Note that you must be logged in as administrator with local admin rights on the remote machine to remotely configure the RAID subsystem. The RAID subsystem's default User Name is "admin" and the Password is "00000000".

<ul style="list-style-type: none"> ● Quick Function ● RaidSet Functions ● VolumeSet Functions ● Physical Drives ● System Controls ● Information 	 XXXXXXXX																																				
<div style="border: 1px solid black; padding: 5px;"> <p>Raid Set Hierarchy</p> <table border="1" style="width: 100%; border-collapse: collapse;"> <thead> <tr> <th>Raid Set</th> <th>IDE Channels</th> <th>Volume Set(Ch/Drv#)</th> <th>Volume State</th> <th>Capacity</th> </tr> </thead> <tbody> <tr> <td> </td> <td> </td> <td> </td> <td> </td> <td> </td> </tr> </tbody> </table> </div>		Raid Set	IDE Channels	Volume Set(Ch/Drv#)	Volume State	Capacity																															
Raid Set	IDE Channels	Volume Set(Ch/Drv#)	Volume State	Capacity																																	
<div style="border: 1px solid black; padding: 5px;"> <p>IDE Channels</p> <table border="1" style="width: 100%; border-collapse: collapse;"> <thead> <tr> <th>Channel</th> <th>Usage</th> <th>Capacity</th> <th>Model</th> </tr> </thead> <tbody> <tr><td>Ch01</td><td>Free</td><td>300.1GB</td><td>WDC WD3000HLFS-01G6U0</td></tr> <tr><td>Ch02</td><td>Free</td><td>300.1GB</td><td>WDC WD3000HLFS-01G6U0</td></tr> <tr><td>Ch03</td><td>Free</td><td>300.1GB</td><td>WDC WD3000HLFS-01G6U0</td></tr> <tr><td>Ch04</td><td>Free</td><td>300.1GB</td><td>WDC WD3000HLFS-01G6U0</td></tr> <tr><td>Ch05</td><td>Free</td><td>300.1GB</td><td>WDC WD3000HLFS-01G6U0</td></tr> <tr><td>Ch06</td><td>Free</td><td>300.1GB</td><td>WDC WD3000HLFS-01G6U0</td></tr> <tr><td>Ch07</td><td>Free</td><td>300.1GB</td><td>WDC WD3000HLFS-01G6U0</td></tr> <tr><td>Ch08</td><td>Free</td><td>300.1GB</td><td>WDC WD3000HLFS-01G6U0</td></tr> </tbody> </table> </div>		Channel	Usage	Capacity	Model	Ch01	Free	300.1GB	WDC WD3000HLFS-01G6U0	Ch02	Free	300.1GB	WDC WD3000HLFS-01G6U0	Ch03	Free	300.1GB	WDC WD3000HLFS-01G6U0	Ch04	Free	300.1GB	WDC WD3000HLFS-01G6U0	Ch05	Free	300.1GB	WDC WD3000HLFS-01G6U0	Ch06	Free	300.1GB	WDC WD3000HLFS-01G6U0	Ch07	Free	300.1GB	WDC WD3000HLFS-01G6U0	Ch08	Free	300.1GB	WDC WD3000HLFS-01G6U0
Channel	Usage	Capacity	Model																																		
Ch01	Free	300.1GB	WDC WD3000HLFS-01G6U0																																		
Ch02	Free	300.1GB	WDC WD3000HLFS-01G6U0																																		
Ch03	Free	300.1GB	WDC WD3000HLFS-01G6U0																																		
Ch04	Free	300.1GB	WDC WD3000HLFS-01G6U0																																		
Ch05	Free	300.1GB	WDC WD3000HLFS-01G6U0																																		
Ch06	Free	300.1GB	WDC WD3000HLFS-01G6U0																																		
Ch07	Free	300.1GB	WDC WD3000HLFS-01G6U0																																		
Ch08	Free	300.1GB	WDC WD3000HLFS-01G6U0																																		

Main Menu

The main menu shows all available functions that enable the user to execute actions or display information by clicking on the appropriate link.

Menu Category	Description
Quick Function	Create a RAID configuration, which consists of all physical disks installed. The Volume Set Capacity, Raid Level, and Stripe Size can be modified during setup.
Raid Set Functions	Create customized Raid Sets.
Volume Set Functions	Create customized Volume Sets and allow modification of parameters of existing Volume Sets.
Physical Drives	Enables creation of pass through disks and allow modification of parameters of existing pass through drives. This also provides a function to identify a selected disk drive.
System Controls	For setting the RAID system configurations.
Information	To view the controller and hardware monitor information. The Raid Set hierarchy can also be viewed through the Raid Set Hierarchy item.

Configuration Procedures

Below are a few practical examples of concrete configuration procedures.

3.5 Quick Create

The number of physical drives in the RAID subsystem determines the RAID levels that can be implemented within the Raid Set. You can create a Raid Set associated with exactly one Volume Set. The user can change the RAID level, Capacity, Volume Initialization Mode and Stripe Size. A hot spare option is also created depending upon the existing configuration. Tick on the **Confirm The Operation** and click on the **Submit** button in the Quick Create screen, the Raid Set and Volume Set will start to initialize.

If the Volume Set size is over 2TB, an option "Greater Two TB Volume Support" will be automatically provided in the screen as shown in the above example. There are two options to select: "No" and "Yes".

Greater Two TB Volume Support:

No: Volume Set capacity is set to maximum 2TB.

Yes: Volume Set capacity can be set over 2TB.



NOTE: In Quick Create, the Raid Set is automatically configured based on the number of disks in your system. Use the Raid Set Function and Volume Set Function if you prefer to customize your Raid Set and Volume Set.



NOTE: When Quick Create is used, the Volume Set will be mapped by default to both host channels "SATA&USB/0". The eSATA1/USB/1394b and USB cannot use at the same time. After the initialization is done, please use the Modify Volume Set function to modify the host channel as you need.

3.6 Raid Set Functions

Use the Raid Set Function and Volume Set Function if you prefer to customize your system. User can manually configure and has full control of the Raid Set and Volume Set setting, but it will take longer to set up than when using the Quick Create function. Select the Raid Set Function to manually configure the Raid Set for the first time or to delete existing Raid Set and reconfigure a Raid Set. The maximum number of RAID Sets that can be created depends on the number of disk channels in the RAID subsystem. For 8-bay RAID subsystem, eight Raid Sets can be created.

3.6.1 Create Raid Set

RAID Manager XXXXXXXX

Select The IDE Drives For RAID Set

Select	Channel	Capacity	Model
<input checked="" type="checkbox"/>	IDE Ch01	300.1GB	WDC WD3000HLFS-01G6U0
<input checked="" type="checkbox"/>	IDE Ch02	300.1GB	WDC WD3000HLFS-01G6U0
<input checked="" type="checkbox"/>	IDE Ch03	300.1GB	WDC WD3000HLFS-01G6U0
<input checked="" type="checkbox"/>	IDE Ch04	300.1GB	WDC WD3000HLFS-01G6U0
<input checked="" type="checkbox"/>	IDE Ch05	300.1GB	WDC WD3000HLFS-01G6U0
<input checked="" type="checkbox"/>	IDE Ch06	300.1GB	WDC WD3000HLFS-01G6U0
<input checked="" type="checkbox"/>	IDE Ch07	300.1GB	WDC WD3000HLFS-01G6U0
<input type="checkbox"/>	IDE Ch08	300.1GB	WDC WD3000HLFS-01G6U0

Raid Set Name:

Confirm The Operation

To create a Raid Set, click on the **Create Raid Set** link. A "Select The IDE Drives For RAID Set" screen is displayed showing the IDE drives in the RAID subsystem. Check the "Select" option to include a physical drive to the current Raid Set. Enter the preferred Raid Set Name (1 to 16 alphanumeric characters) to define a unique identifier for the Raid Set. The default Raid Set name will always appear as Raid Set # 00 for first Raid Set.

Tick on the **Confirm The Operation** option and click on the **Submit** button in the screen. The Raid Set will start to initialize.

3.6.2 Delete Raid Set

To delete a Raid Set, click on the **Delete Raid Set** link. A "Select The RAID SET To Delete" screen is displayed showing all Raid Sets existing in the current subsystem. Check the Raid Set number you want to delete in the Select column.

Tick on the **Confirm The Operation** option and click on the **Submit** button to process with deletion.



●Quick Function

●RaidSet Functions

- Create Raid Set
- Delete Raid set
- Expand Raid Set
- Offline Raid set
- Activate Raid Set
- Create Hot Spare
- Delete Hot Spare
- Rescue Raid Set

●VolumeSet Functions

●Physical Drives

●System Controls

●Information

RAID Manager XXXXXXXX

Select The Raid Set To Delete

Select	Raid Set Name	Member Disks	Raid State	Capacity
<input checked="" type="radio"/>	Raid Set # 00	7/7	Normal	2100.5GB

Confirm The Operation, VolumeSet In This RaidSet Will Also Be Deleted

Submit Reset

3.6.3 Expand Raid Set

Use this option to expand a Raid Set when one or more disk drives is/are added to the subsystem. This function is active when at least one drive is available.

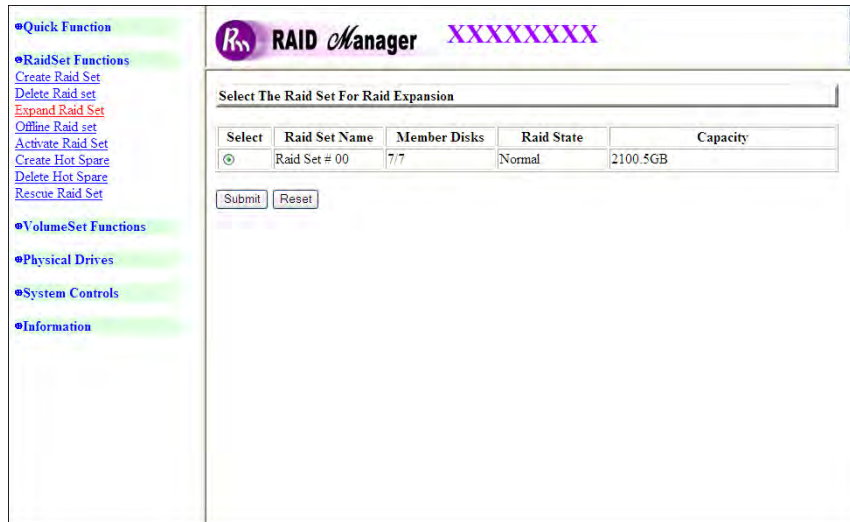

To expand a Raid Set, click on the **Expand Raid Set** link. Select the Raid Set which you want to expand.

Tick on the available disk(s) and check **Confirm The Operation**. Click on the **Submit** button to add the selected disk(s) to the Raid Set.



NOTE: Once the Expand Raid Set process has started, user cannot stop it. The process must be completed.



NOTE: If a disk drive fails during Raid Set expansion and a hot spare is available, an auto rebuild operation will occur after the Raid Set expansion is completed.

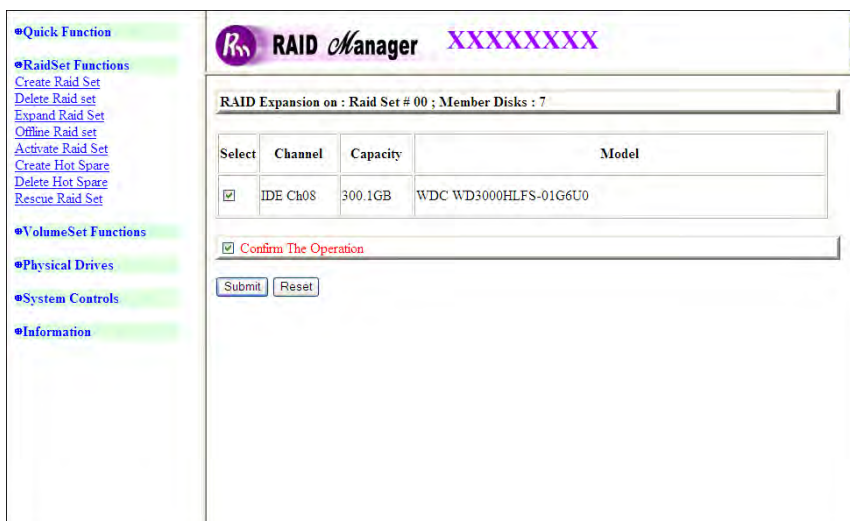

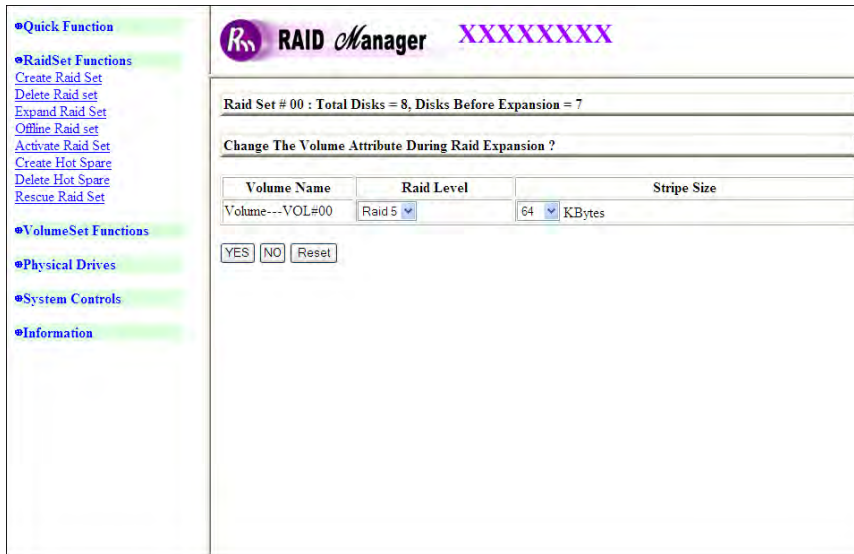

Migration occurs when a disk is added to a Raid Set. Migrating status is displayed in the Raid Set status area of the Raid Set information. Migrating status is also displayed in the Volume Set status area of the Volume Set Information for all Volume Sets under the Raid Set which is migrating.

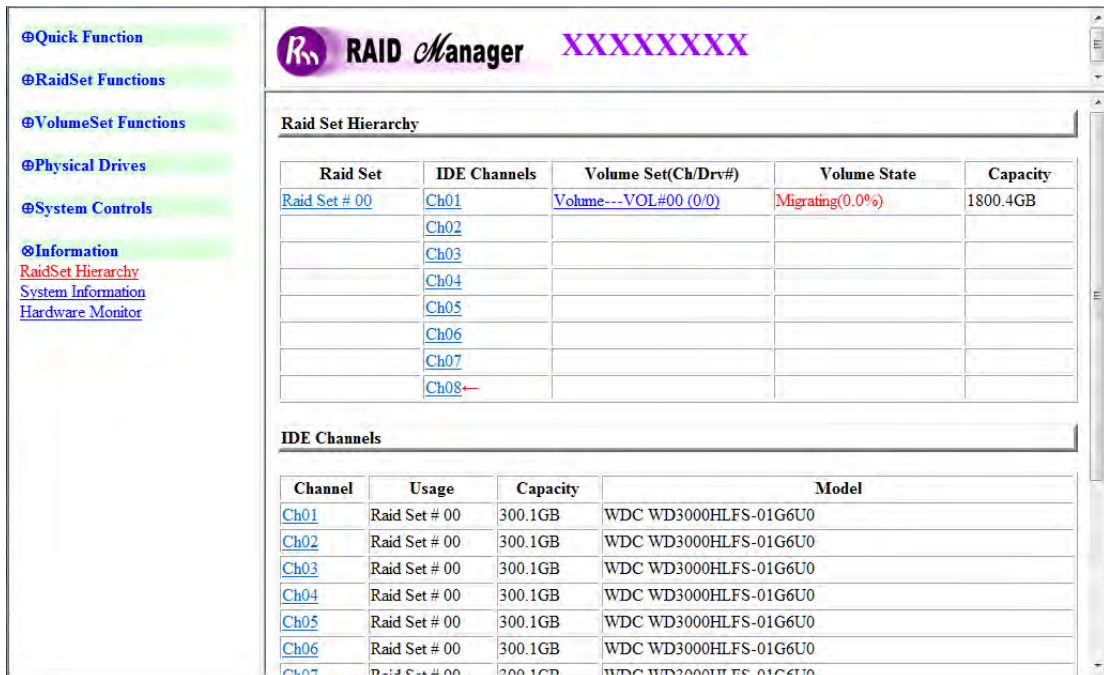

3.6.4 Offline Raid Set

If user wants to offline (and move) a Raid Set while the RAID subsystem is powered on, use the Offline Raid Set function. After completing the function, the HDD state will change to “Offline” Mode.

To offline a Raid Set, click on the **Offline Raid Set** link. A “Select The RAID SET To Offline” screen is displayed showing all existing Raid Sets in the subsystem. Select the Raid Set which you want to offline in the Select column.

Tick on the **Confirm The Operation**, and then click on the **Submit** button to offline the selected Raid Set.

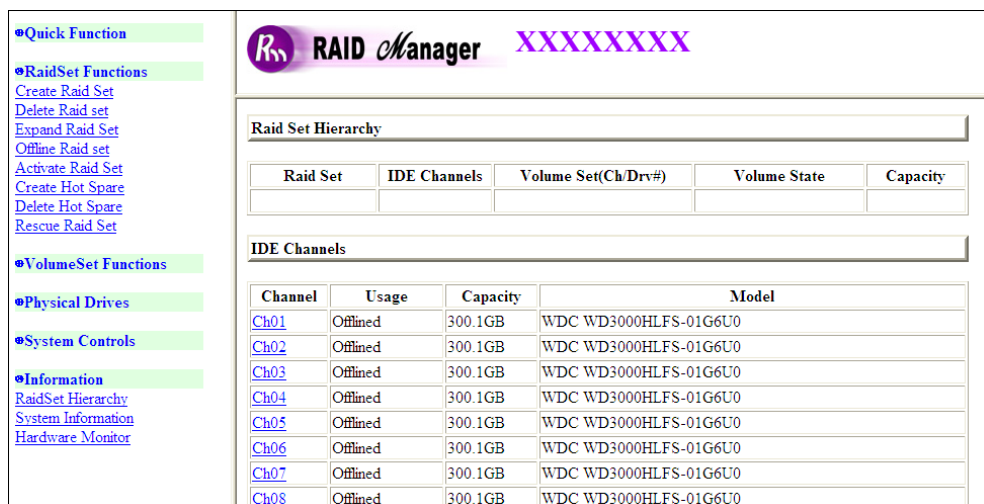
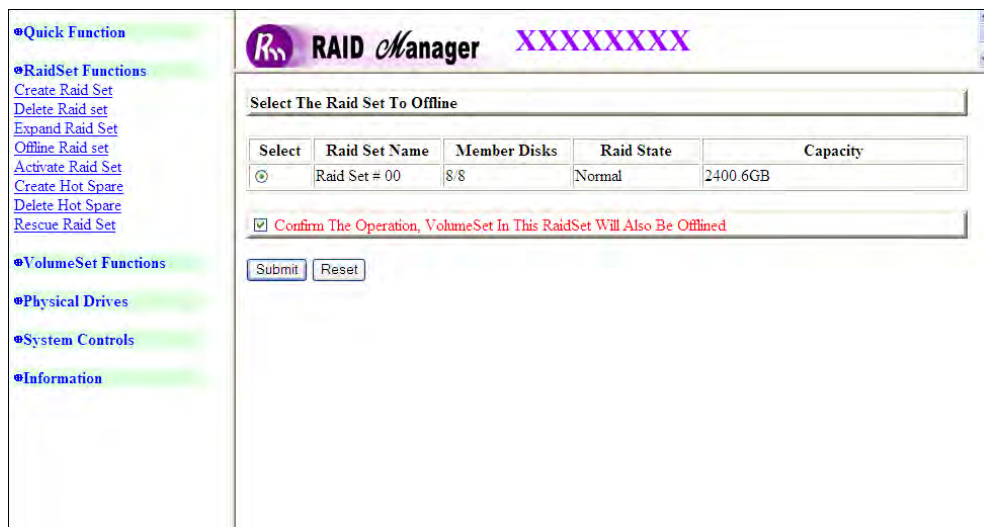

NOTE: After completing the Offline Raid Set Function, all the LEDs of the physical HDDs belonging to this Raid Set will be blinking red.

3.6.5 Activate Incomplete Raid Set

When Raid Set State is “**Normal**”, this means there is no failed disk drive.

Raid Set Information	
Raid Set Name	Raid Set # 00
Member Disks	3
Total Raw Capacity	240.0GB
Free Raw Capacity	0.0GB
Min Member Disk Size	80.0GB
Raid Set Power State	Operating
Raid Set State	Normal

When does “Incomplete” Raid Set State Happens?

If the RAID subsystem is powered off and one disk drive is removed or has failed in power off state, and when the RAID subsystem is powered on, the Raid Set State will change to “**Incomplete**”.

Raid Set Information	
Raid Set Name	Raid Set # 00
Member Disks	8
Total Raw Capacity	2400.6GB
Free Raw Capacity	0.0GB
Min Member Disk Size	300.1GB
Raid Set Power State	Operating
Raid Set State	Incomplete

The Volume Set will not be visible and the failed or removed disk will be shown as “**Missing**”.

Raid Set Hierarchy				
Raid Set	IDE Channels	Volume Set(Port/Lun)	Volume State	Capacity
Raid Set # 00	Ch01			
	Ch02			
	Missing			

IDE Channels			
Channel	Usage	Capacity	Model
Ch01	Raid Set # 00	203.9GB	Maxtor 6Y200M0
Ch02	Raid Set # 00	122.9GB	Maxtor 6Y120M0
Ch03	N.A.	N.A.	N.A.

When is the “Activate Raid Set” function can be used?

In order to access the Volume Set and corresponding data, use the **Activate Raid Set** function to activate the Raid Set. After selecting this function, the Raid State will change to “**Degraded**” state.

To activate the incomplete the Raid Set, click on the **Activate Raid Set** link. A “Select The Raid Set To Activate” screen is displayed showing all existing Raid Sets in the subsystem. Select the Raid Set with “**Incomplete**” state which you want to activate in the Select column.

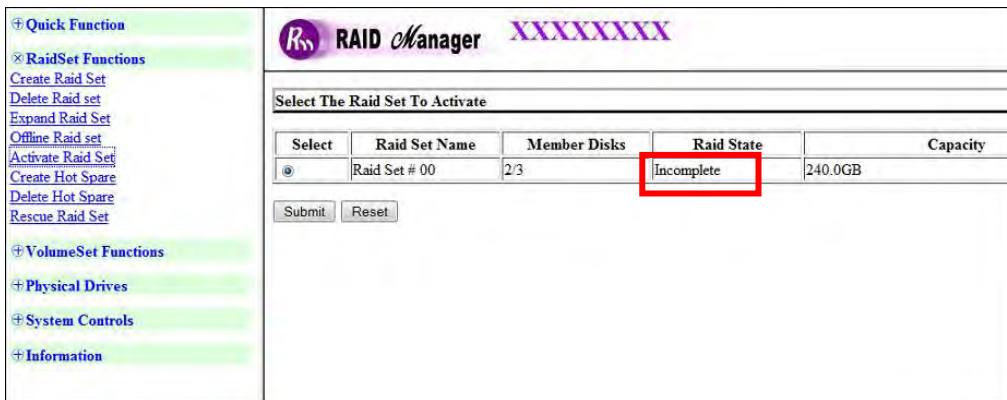

Click on the **Submit** button to activate the Raid Set. The Volume Set(s) associated with the Raid Set will become accessible in “**Degraded**” mode.

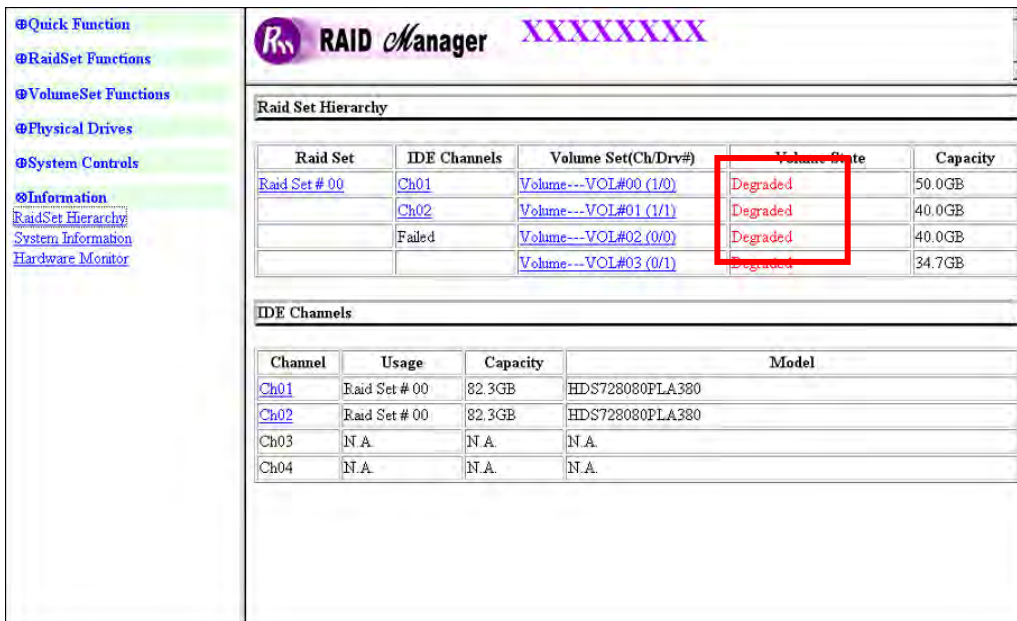

NOTE: The “Activate Raid Set” function is only used when Raid Set State is “Incomplete”. It cannot be used when Raid Set configuration is lost. If ever the Raid Set configuration is lost, please contact your vendor for support.

3.6.6 Create Hot Spare

The Create Hot Spare option gives you the ability to define a global hot spare.

When you choose the **Create Hot Spare** option in the Raid Set Function, all unused (non Raid Set member) disk drives in the subsystem appear. Select the target disk drive by clicking on the appropriate check box. Tick on the **Confirm The Operation** and click on the **Submit** button to create hot spare drive(s).

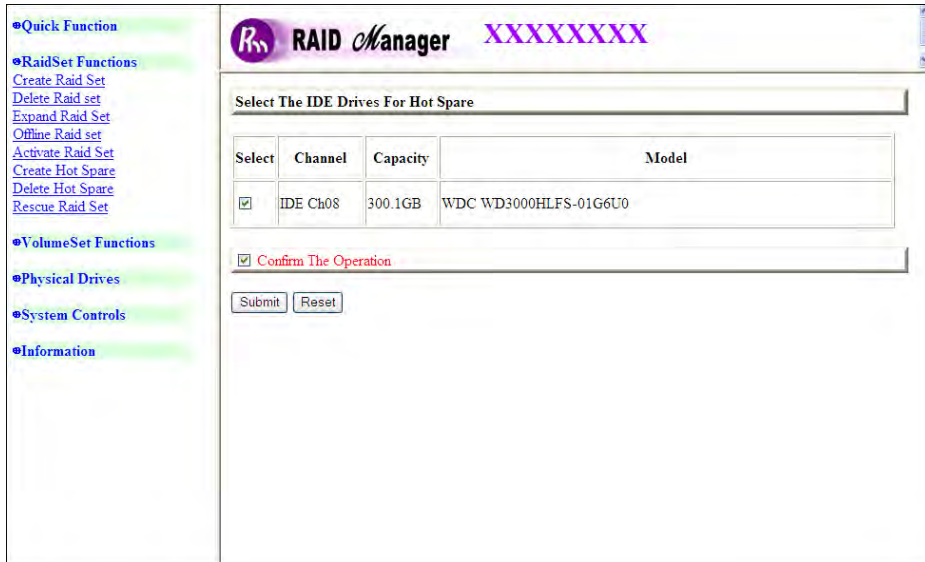

3.6.7 Delete Hot Spare

Use this option to remove the Hot Spare function from a disk drive.

Click the Delete Hot Spare function then select the Hot Spare Disk. Tick on the **Confirm The Operation**, and click on the **Submit** button in the screen to delete the hot spare disk.

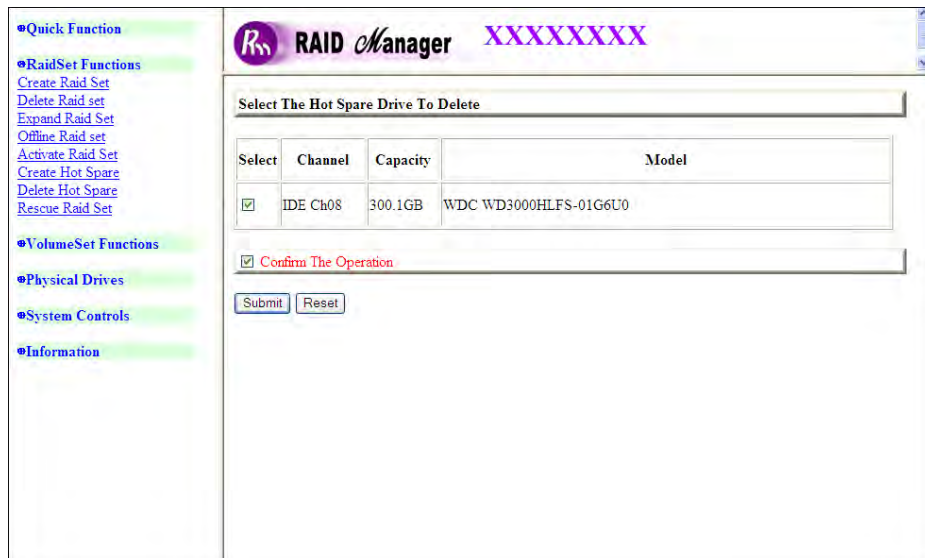

3.6.8 Rescue Raid Set

If you need to rescue a missing Raid Set, please contact your vendor for support or assistance.

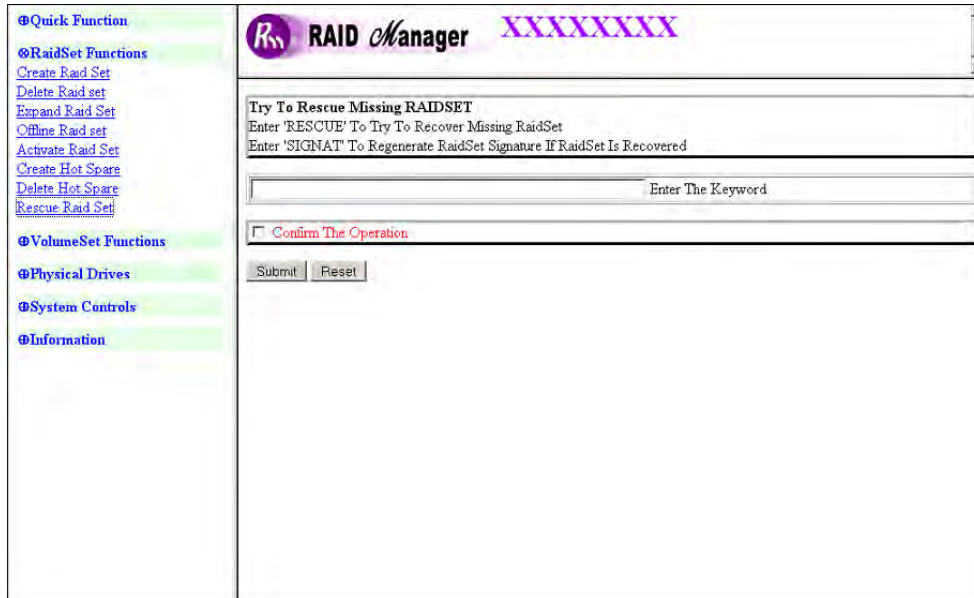

3.7 Volume Set Function

A Volume Set is seen by the host system as a single logical device. It is organized in a RAID level with one or more physical disks. RAID level refers to the level of data performance and protection of a Volume Set. A Volume Set capacity can consume all or a portion of the raw capacity available in a Raid Set.

Multiple Volume Sets can exist on a group of disks in a Raid Set. Additional Volume Sets created in a specified Raid Set will reside on all the physical disks in the Raid Set. Thus each Volume Set on the Raid Set will have its data spread evenly across all the disks in the Raid Set.

3.7.1 Create Volume Set

The following are the Volume Set features:

1. Volume sets of different RAID levels may coexist on the same Raid Set.
2. Up to 16 Volume Sets in a Raid Set can be created by the RAID subsystem controller.

To create Volume Set from a Raid Set, expand the Volume Set Functions in the main menu and click on the **Create Volume Set** link. The **Select The Raid Set To Create Volume On It** screen will show all existing Raid Sets. Tick on the Raid Set where you want to create the Volume Set and then click on the **Submit** button.

Configure the Volume Set name, Capacity, RAID level, Stripe Size, Cache Mode, Initialization Mode (if needed), SATA Data Xfer Mode, and Channel/Drive#.



The screenshot shows the RAID Manager interface with the following configuration details:

Enter Volume Attribute On Raid Set # 00	
Volume Name	Volume---VOL#00
Member Disks	8
Volume Raid Level	Raid 5
Max Capacity Allowed	1750 GB
Select Volume Capacity	1750 GB
Volume Initialization Mode	Foreground Initialization
Volume Stripe Size	64 KBytes
Volume Cache Mode	Write Back
SATA Data Xfer Mode	SATA300+NCQ
Channel Drive#	SATA (CH0) : 1

Additional information displayed at the bottom of the configuration window:

- sSATA Port#0 : Drv#0~7
- sSATA Port#1 : Drv#8~15
- Port Multiplier Supported Host SATA Port Is Needed To Recognize Drv#1~7 And Drv#9~15
- USB : USBiA Drv#0~7 as LUN#0~7 (must start from 0)
- iSCSI/AoE : USBiA Drv#8~15 as TargNode#8~15

Volume Name:

The default Volume Set name will always appear as Volume---VOL#00. You can rename the Volume Set name provided it does not exceed the 16 characters limit.

Raid Level:

Set the RAID level for the Volume Set. Click the down-arrow in the drop-down list. The available RAID levels for the current Volume Set are displayed. Select the preferred RAID level.

Capacity:

The maximum Volume Set size is displayed by default. If necessary, change the Volume Set size appropriate for your application.

Greater Two TB Volume Support:

If the Volume Set size is over 2TB, an option "Greater Two TB Volume Support" will be automatically provided in the screen as shown in the above example. There are two options to select: "No" and "Yes".

No: Volume Set capacity is set to maximum 2TB.

Yes: Volume Set capacity can be set over 2TB.

Initialization Mode:

Set the Initialization Mode for the Volume Set. Foreground mode is completed faster but Volume Set but be completed before it becomes accessible. Background mode makes the Volume Set available instantly but the initialization process takes longer.

Stripe Size:

This parameter sets the size of the stripe written to each disk in a RAID 0, 1, 10, 5, and 6 Volume Set. You can set the Stripe Size to 4 KB, 8 KB, 16 KB, 32 KB, 64 KB, or 128 KB.

A larger Stripe Size produces better read performance, especially if the host server does mostly sequential reads. However, if you are sure that the host server does random reads more often, select a small Stripe Size.



NOTE: Stripe Size in RAID level 3 can't be modified.

Cache Mode:

The RAID subsystem supports Write-Through Cache and Write-Back Cache.

SATA Data Xfer Mode

The RAID subsystem supports SATA150, SATA150+NCQ, SATA300, and SATA300+NCQ data transfer mode.

Channel

Select the Host Channel for mapping the Volume Set. Options are: SATA (CH0), USBiA (CH1), and SATA&USBiA.



NOTE: Select "SATA (CH0)" channel when Volume Set will be mapped to eSATA0/USB 2.0/IEEE 1394b, or eSATA1. Select "USBiA(CH1)" channel when Volume Set will be mapped to the other USB 2.0 Port or accessed via iSCSI/AoE.

Drive #

For eSATA Port0, Drive # options are 0 to 7 (The drive# is assigned in order).

For eSATA Port1, Drive # options are 8 to 15 (Manual Assignment).

For USB Port, Drive # options are 0 to 7.

For iSCSI/AoE, Drive # options are 8 to 15.



NOTE: The eSATA HBA or controller in the host system must support port multiplier to recognize other Volume Sets mapped as Drives 1 to 7 and 8 to 15. Example of eSATA controllers that support port multiplier are Sil3132 or 3124 and Intel ICH9 or ICH10.

Host Channel Port	The Maximum Number of Volume Sets
eSATA Port0 / USB 2.0 Port0 / IEEE 1394b Ports	1 / 2 / 2
eSATA Port1	8
USB 2.0 Port1	8
iSCSI/AoE (R-Link Port)	8



IMPORTANT! It is not recommended to use iSCSI together with eSATA/USB at the same time since access to Volumes can be slower than normal. Using eSATA and USB at the same time is ok.



NOTE: In order to maintain the system I/O performance, it is not recommended to access the storage from the different host interfaces at the same time.

3.7.2 Delete Volume Set

To delete a Volume Set, select the Volume Set Functions in the main menu and click on the **Delete Volume Set** link. The **Select The Volume Set To Delete** screen will show all available Raid Sets. Tick on a Raid Set and check the **Confirm The Operation** option and then click on the **Submit** button to show all Volume Sets in the selected Raid Set. Tick on a Volume Set and check the **Confirm The Operation** option. Click on the **Submit** button to delete the Volume Set.

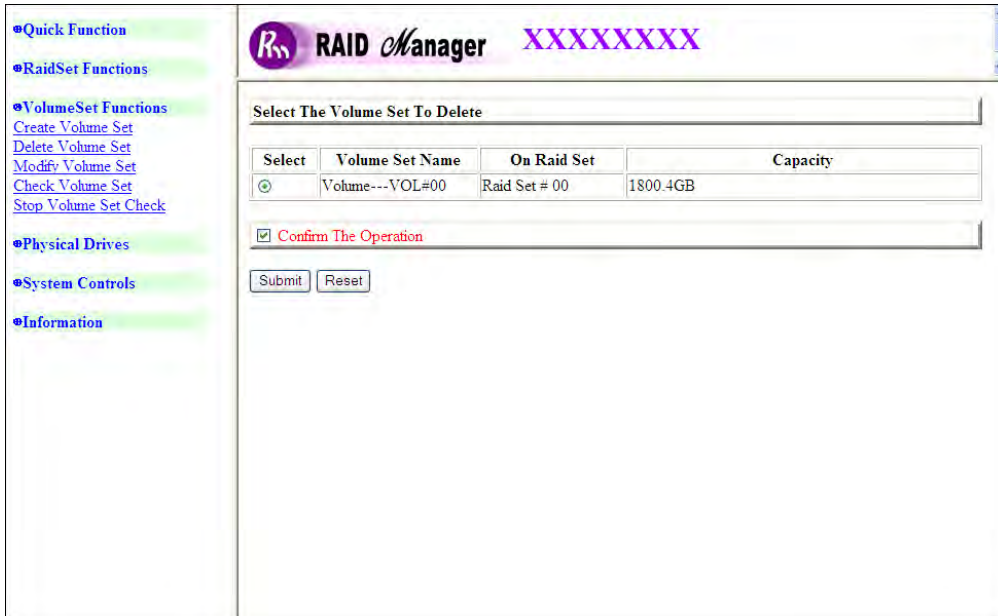

The screenshot displays the RAID Manager web interface. The left sidebar contains a navigation menu with the following items:

- Quick Function
- RaidSet Functions
- VolumeSet Functions
 - Create Volume Set
 - Delete Volume Set
 - Modify Volume Set
 - Check Volume Set
 - Stop Volume Set Check
- Physical Drives
- System Controls
- Information

The main content area is titled "Select The Volume Set To Delete". It features a table with the following data:

Select	Volume Set Name	On Raid Set	Capacity
<input checked="" type="checkbox"/>	Volume---VOL#00	Raid Set # 00	1800.4GB

Below the table, there is a checkbox labeled "Confirm The Operation" which is checked. At the bottom of the form, there are two buttons: "Submit" and "Reset".

3.7.3 Modify Volume Set

Use this function to modify Volume Set configuration.

To modify the attributes of a Volume Set:

1. Click on the **Modify Volume Set** link.
2. Tick from the list the Volume Set you want to modify. Click on the **Submit** button.

The following screen appears.

Select	Volume Set Name	On Raid Set	Capacity
<input checked="" type="checkbox"/>	Volume---VOL#00	Raid Set # 00	1800.4GB

To modify Volume Set attribute values, select an attribute item and click on the attribute value. After completing the modification, tick on the **Confirm The Operation** option and click on the **Submit** button to save the changes.

Volume Name	Volume--VOL#00
Max Capacity Allowed	2199.0 GB
Volume Capacity	2199.0 GB
Volume Initialization Mode	Foreground Initialization
Volume Raid Level	Raid 6
Volume Stripe Size	64 KBytes
Volume Cache Mode	Write Back
SATA Data Xfer Mode	SATA300+NCQ
Channel Drive#	SATA (CH0) : 0

Confirm The Operation



NOTE: Select "SATA" channel when Volume Set will be mapped to eSATA0/USB 2.0/IEEE 1394b, or eSATA1. Select "USB" channel when Volume Set will be mapped to the other USB 2.0 Port.

Drive # Options

For eSATA Port0, Drive # options are 0 to 7.

For eSATA Port1, USB2.0 Port, or IEEE 1394b ports, Drive # options are 8 to 15.

For the other USB 2.0 Port, Drive # options are 0 to 15.

3.7.3.1 Volume Expansion

Volume Capacity (Logical Volume Concatenation Plus Re-stripe)

Use the Expand Raid Set function to expand a Raid Set when a disk is added to your subsystem. (Refer to Section 3.6.3)

The expanded capacity can be used to enlarge the Volume Set size or create another Volume Set. Use the Modify Volume Set function to expand the Volume Set capacity. Select the Volume Set and move the cursor to the **Volume Set Capacity** item and enter the capacity size.



NOTE: Only the last created Volume Set can be expanded.

Tick on the **Confirm The Operation** and click on the **Submit** button to complete the action. The Volume Set starts to expand.

3.7.4 Volume Set Migration

Migration occurs when a Volume Set migrates from one RAID level to another, a Volume Set stripe size changes, or when a disk is added to a Raid Set. Migrating status is displayed in the Volume Set status area of the RaidSet Hierarchy screen during migration.

The screenshot shows the RAID Manager interface. On the left is a navigation menu with options like Quick Function, RAID Set Functions, Volume Set Functions, Physical Drives, System Controls, and Information. The main area displays the RAID Set Hierarchy and IDE Channels.

Raid Set	IDE Channels	Volume Set(Ch/Drv#)	Volume State	Capacity
Raid Set # 00	Ch01	Volume---VOL#00 (0/0)	Migrating(0.0%)	1800.4GB
	Ch02			
	Ch03			
	Ch04			
	Ch05			
	Ch06			
	Ch07			
	Ch08			

Channel	Usage	Capacity	Model
Ch01	Raid Set # 00	300.1GB	WDC WD3000HLFS-01G6U0
Ch02	Raid Set # 00	300.1GB	WDC WD3000HLFS-01G6U0
Ch03	Raid Set # 00	300.1GB	WDC WD3000HLFS-01G6U0
Ch04	Raid Set # 00	300.1GB	WDC WD3000HLFS-01G6U0
Ch05	Raid Set # 00	300.1GB	WDC WD3000HLFS-01G6U0
Ch06	Raid Set # 00	300.1GB	WDC WD3000HLFS-01G6U0
Ch07	Raid Set # 00	300.1GB	WDC WD3000HLFS-01G6U0

3.7.5 Check Volume Set

Use this function to perform Volume Set consistency check, which verifies the correctness of redundant data (data blocks and parity blocks) in a Volume Set. This basically means computing the parity from the data blocks and comparing the results to the contents of the parity blocks, or computing the data from the parity blocks and comparing the results to the contents of the data blocks.

To perform Check Volume Set function:

1. Click on the **Check Volume Set** link.
2. Tick from the list the Volume Set you want to check. Tick on **Confirm The Operation** and click on the **Submit** button. The Checking process will be started.

Check Volume Set Options:

- ✓ Scrub Bad Block If Bad Block Found, Assume Parity Data is Good
- ✓ Re-compute Parity if Parity Error, Assume Data is Good



NOTE: When the 2 options are not selected, it will only check for errors. It is recommended to perform Check Volume Set with the 2 options unselected at first. If the result shows errors, the data must be backed up to a safe storage. Then the two options can be selected and redo Check Volume Set to correct the errors.

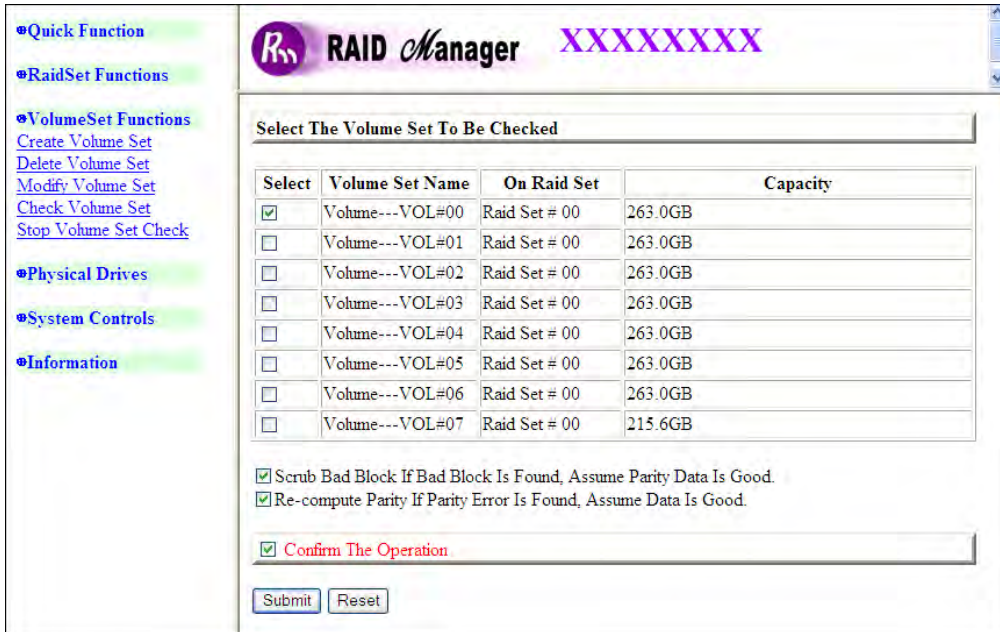

The checking percentage can also be viewed by clicking on RaidSet Hierarchy in the main menu.

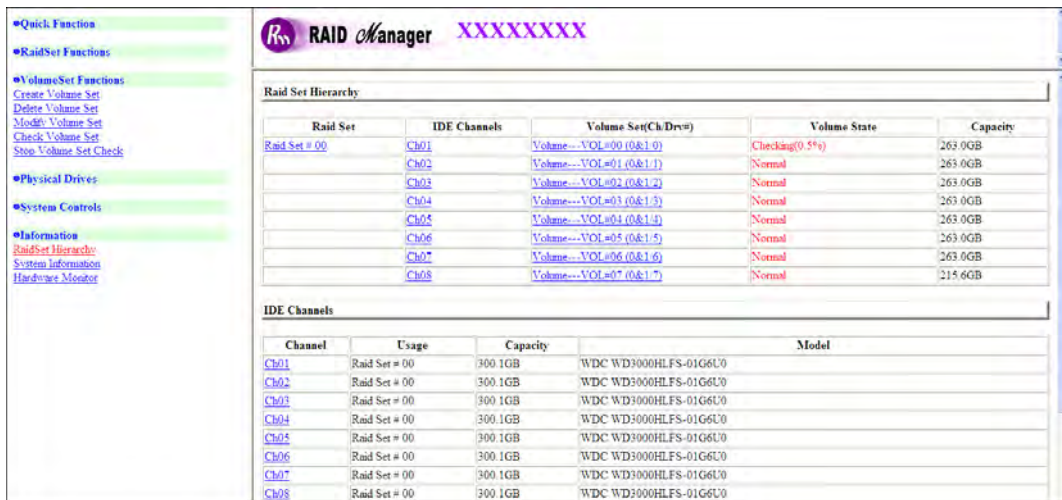

3.7.6 Stop Volume Set Check

Use this option to stop the current running Check Volume Set process.

<ul style="list-style-type: none">•Quick Function•RaidSet Functions•VolumeSet Functions<ul style="list-style-type: none">Create Volume SetDelete Volume SetModify Volume SetCheck Volume SetStop Volume Set Check•Physical Drives•System Controls•Information	<div style="text-align: center;"> RAID Manager XXXXXXXX</div> <hr/> <p>Do You Want To Stop All Volume Consistency Checking?</p> <p><input type="checkbox"/> Confirm The Operation</p> <p><input type="button" value="Submit"/> <input type="button" value="Reset"/></p>
--	---

3.8 Physical Drive

Choose this option from the Main Menu to select a disk drive and to perform the operations listed below.

3.8.1 Create Pass-Through Disk

A Pass-Through Disk is a disk drive not controlled by the internal RAID subsystem firmware and thus cannot be a part of a Volume Set. A Pass-Through disk is a separate and individual Raid Set. The disk is available to the host as an individual disk. It is typically used on a system where the operating system is on a disk not controlled by the RAID firmware.

To create pass-through disk, click on the **Create Pass-Through** link under the Physical Drives main menu. The setting function screen appears.

Select the disk drive to be made as Pass-Through Disk and configure the Pass-Through Disk attributes, such as the Cache Mode, SATA Data Xfer Mode and Channel: IDE Drive# for this volume.

RAID Manager XXXXXXXX

Select the IDE drive For Pass Through

Select	Channel	Capacity	Model
<input checked="" type="radio"/>	IDE Ch08	300.1GB	WDC WD3000HLFS-01G6U0

Enter Pass Through Disk Attribute

Volume Cache Mode: Write Back

SATA Data Xfer Mode: SATA300+NCQ

Channel: Drive#: SATA : 0

sSATA Port#0 : Drv#0~7
sSATA Port#1 : Drv#8~15
Port Multiplier Supported Host SATA Port Is Needed To
Recognize Drv#1~7 And Drv#9~15

USB : USBiA Drv#0~7 as LUN#0~7 (must start from 0)
iSCSI/AoE : USBiA Drv#8~15 as TargNode#8~15

Confirm The Operation

Submit Reset

3.8.2 Modify Pass-Through Disk

Use this option to modify the Pass-Through Disk attributes. User can modify the Cache Mode, SATA Data Xfer Mode and Channel: Drive#.

To modify the Pass-Through drive attribute from the Pass-Through drive pool, click on the **Modify Pass-Through** link. The "Select The Pass-Through Disk For Modification" screen appears. Tick on the Pass-Through Disk from the Pass-Through drive pool and click on the **Submit** button to select the drive.

The screenshot shows the RAID Manager interface. On the left is a navigation menu with categories: Quick Function, RaidSet Functions, VolumeSet Functions, Physical Drives (with sub-links: Create Pass Through, Modify Pass Through, Delete Pass Through, Identify Drive), System Controls, and Information. The main area is titled 'RAID Manager XXXXXXXX' and contains a section 'Select The Pass Through Disk For Modification'. Below this is a table with columns: Select, Channel, Capacity, and Model. One row is visible with a radio button selected, Channel 'IDE Ch08', Capacity '300.1GB', and Model 'WDC WD3000HLFS-01G6U0'. At the bottom of the table area are 'Submit' and 'Reset' buttons.

Select	Channel	Capacity	Model
<input checked="" type="radio"/>	IDE Ch08	300.1GB	WDC WD3000HLFS-01G6U0

The Enter Pass-Through Disk Attribute screen appears. Modify the drive attribute values as you want.

The screenshot shows the RAID Manager interface for the 'Enter Pass Through Disk Attribute' screen. The left navigation menu is the same as in the previous screenshot. The main area is titled 'RAID Manager XXXXXXXX' and contains a section 'Enter Pass Through Disk Attribute'. Below this is a text field containing 'Ch08 300.1GB WDC WD3000HLFS-01G6U0'. There are three dropdown menus: 'Volume Cache Mode' set to 'Write Back', 'SATA Data Xfer Mode' set to 'SATA300+NCQ', and 'Channel: Drive#' set to 'SATA : 0'. Below these are several lines of red text providing information about SATA and USB ports. At the bottom, there is a checkbox labeled 'Confirm The Operation' which is currently unchecked, and 'Submit' and 'Reset' buttons.

Volume Cache Mode: Write Back
 SATA Data Xfer Mode: SATA300+NCQ
 Channel: Drive#: SATA : 0

sSATA Port#0 : Drv#0~7
 sSATA Port#1 : Drv#8~15
 Port Multiplier Supported Host SATA Port Is Needed To Recognize Drv#1~7 And Drv#9~15

USB : USBiA Drv#0~7 as LUN#0~7 (must start from 0)
 iSCSI/AoE : USBiA Drv#8~15 as TargNode#8~15

To save changes, tick on **Confirm The Operation** and click on the **Submit** button.

3.8.3 Delete Pass-Through Disk

To delete Pass-Through Disk from the Pass-Through drive pool, click on **Delete Pass-Through** link. Select a Pass-Through Disk, tick on the **Confirm The Operation** and click the **Submit** button to complete the delete action.

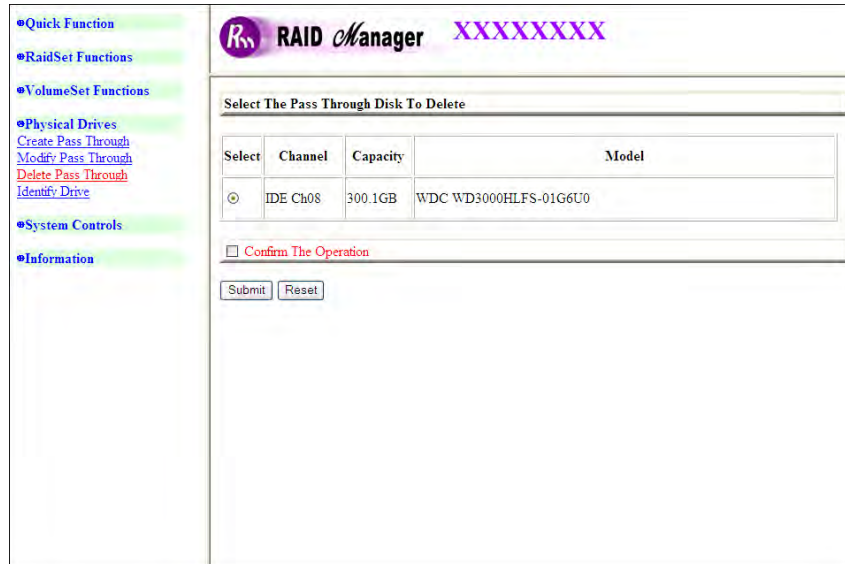

3.8.4 Identify Selected Drive

Use this option to physically locate a selected drive to prevent removing the wrong drive. When a disk drive is selected using the **Identify Drive** function, the LED of the selected disk drive will light.

To identify a selected drive from the drives pool, click on the **Identify Drive** link. The “Select The IDE Drive For identification” screen appears. Tick on the disk drive from the drives list. After completing the selection, click on the **Submit** button to identify selected drive.

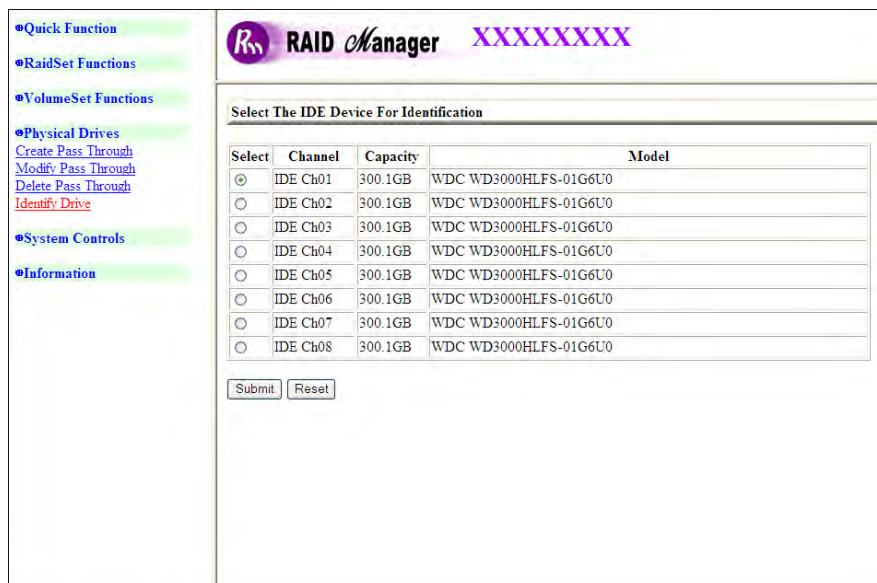

3.9 System Controls

3.9.1 System Configuration

To set the RAID subsystem system configuration options, click the **System Config** link under the **System Controls** menu. The System Configuration screen will be shown. Set the system configuration option as needed.

The screenshot shows the RAID Manager System Configurations screen. The sidebar on the left contains the following links:

- Quick Function
- RaidSet Functions
- VolumeSet Functions
- Physical Drives
- System Controls
 - System Config**
 - iSCSI Config
 - EtherNet Config
 - Alert By Mail Config
 - SNMP Configuration
 - NTP Configuration
 - View Events/Mute Beeper
 - Generate Test Event
 - Clear Event Buffer
 - Modify Password
 - Upgrade Firmware
 - Shutdown Controller
 - Restart Controller
- Information

The main panel, titled "System Configurations", contains the following settings:

System Beeper Setting	Enabled
Background Task Priority	Medium(50%)
Terminal Port Configuration	Baud Rate 115200, Stop Bits 1
JBOD/RAID Configuration	RAID
Max SATA Mode Supported	SATA300+NCQ
Host NCQ Mode Setting	Disabled
HDD Read Ahead Cache	Enabled
Volume Data Read Ahead	Normal
Stagger Power On Control	0.7
Spin Down Idle HDD (Minutes)	Disabled
Empty HDD Slot LED	ON
HDD SMART Status Polling	Enabled
Auto Activate Incomplete Raid	Disabled
Disk Capacity Truncation Mode	No Truncation

At the bottom of the main panel, there is a checkbox labeled "Confirm The Operation" and two buttons: "Submit" and "Reset".

System Beeper Setting:

This option is used to Disabled or Enable the subsystem's RAID controller alarm beeper.

Background Task Priority:

The Background Task Priority indicates how much time and system resource the RAID controller devotes to a background task, such as a rebuild operation. The RAID subsystem allows user to choose the background task priority (High 80%, Medium 50%, Low 25%, and Ultra Low 5%) to balance between background task process and Volume Set access. For high RAID subsystem performance, specify a low value.

Terminal Port Configuration:

Baud Rate setting values are 1200, 2400, 4800, 9600, 19200, 38400, 57600, and 115200. Use 115200 for the RAID subsystem terminal port speed setting.

Stop Bits values are 1 bit and 2 bits. Use 1 bit for the RAID subsystem stop bit setting.

Note: Parity value is fixed at "None". Data Bits value is fixed at 8 bits.

JBOD/RAID Configuration

The RAID subsystem supports JBOD and RAID configuration.

Maximum SATA Mode Supported:

The 12 SATA drive channel can support up to SATA II, which runs up to 300MB/s. NCQ is a command protocol in Serial ATA that can only be implemented on native Serial ATA hard drives. It allows multiple commands to be outstanding within a drive at the same time. Drives that support NCQ have an internal queue where outstanding commands can be dynamically rescheduled or re-ordered, along with the necessary tracking mechanisms for outstanding and completed portions of the workload. RAID subsystem allows user to choose the SATA Mode: SATA150, SAT150+NCQ, SAT300, SATA300+NCQ.

Host NCQ Mode Setting:

This option allows the users to select the supported Host NCQ Mode or to disable it. Options are: ESB2/MACPro/SiliconImage, Marvell 6145, ICH, nVidia, and Disabled.

HDD Read Ahead Cache:

This option allows the users to disable the cache of the disk drives in the RAID subsystem. In some HDD models, disabling the cache in the HDD is necessary to prove the RAID subsystem functions correctly.

Volume Data Read Ahead:

This option allows the users to set the Volume Data Read Ahead function. Options are: Normal, Aggressive, Conservative, and Disabled.

Stagger Power On Control:

This option allows the RAID subsystem's power supply to power up in succession each HDD in the RAID subsystem. In the past, all the HDDs on the RAID subsystem are powered up altogether at the same time. This function allows the power transfer time (lag time) from the last HDD to the next one be set within the range of 0.4 to 6.0 seconds.

Spin Down Idle HDD (Minutes): MAID Function

This option enables the hard drives to spin down after they become idle after a preset period of time. Options are: Disabled, 1 (For Test), 3, 5, 10, 15, 20, 30, 40, and 60.

Empty HDD Slot LED:

Use this option to turn ON or OFF the LED of a slot with no HDD.

HDD SMART Status Polling:

The RAID subsystem can read HDD SMART information through this function. This function is enabled by default.

Auto Activate Incomplete Raid:

Use this option to automatically activate an Incomplete Raid Set. Note that the Raid Set status becomes Incomplete when one disk is removed or failed in power off state. After activated, the Volume Set(s) in the Raid Set will be in Degraded mode.

Disk Capacity Truncation Mode:

This RAID subsystem use drive truncation so that drives from different vendors are more likely to be able to be used as spares for each other. Drive truncation slightly decreases the usable capacity of a drive that is used in redundant units. Options are:

Multiples Of 10G: If you have several 120GB drives from different vendors, chances are that the capacity varies slightly. For example, one drive might be 121.1 GB, and the other 120.4 GB. This drive truncation mode makes the 121.1 GB and 120.4 GB drives same capacity as 120 GB so that one could replace the other.

Multiples Of 1G: If you have 120 GB drives from different vendors, chances are that the capacity varies slightly. For example, one drive might be 121.1 GB, and the other 121.4 GB. This drive truncation mode makes the 121.1 GB and 121.4 GB drives same capacity 121 GB so that one could replace the other.

No Truncation: The capacity of the disk drive is not truncated.

3.9.2 iSCSI Configuration

To set the iSCSI Configuration options, click the **iSCSI Config** link under the **System Controls** menu. The iSCSI Configuration screen will be shown. Set the system configuration option as needed.

<ul style="list-style-type: none"> ⊕ Quick Function ⊕ RaidSet Functions ⊕ VolumeSet Functions ⊕ Physical Drives ⊙ System Controls <ul style="list-style-type: none"> System Config iSCSI Config EtherNet Config Alert By Mail Config SNMP Configuration NTP Configuration View Events/Mute Beeper Generate Test Event Clear Event Buffer Modify Password Upgrade Firmware Shutdown Controller Restart Controller ⊕ Information 	 RAID Manager XXXXXXXX			
	<div style="border: 1px solid black; padding: 5px;"> <p>iSCSI Configuration</p> <table border="1" style="width: 100%; border-collapse: collapse;"> <tr> <td style="width: 60%;">iSCSI TargetNode Base Name</td> <td>iqn.1996-08.tw.com.proware:ep2803ua</td> </tr> <tr> <td>iSCSI Port Number (7168..8191 Is Reserved)</td> <td>3260</td> </tr> </table> <p><input type="checkbox"/> Confirm The Operation</p> <p style="text-align: center;"> <input type="button" value="Submit"/> <input type="button" value="Reset"/> </p> </div>	iSCSI TargetNode Base Name	iqn.1996-08.tw.com.proware:ep2803ua	iSCSI Port Number (7168..8191 Is Reserved)
iSCSI TargetNode Base Name	iqn.1996-08.tw.com.proware:ep2803ua			
iSCSI Port Number (7168..8191 Is Reserved)	3260			

iSCSI TargetNode Base Name

This option is used to set the iSCSI target node base name.

iSCSI Port Number (7168..8191 Is Reserved)

This option is used to modify the iSCSI port number to be used in iSCSI connection. Note that port numbers from 7168 to 8191 cannot be used. Port Number can also be changed in EhterNet Config.



NOTE: The new settings will take effect only after next volume change/login.

New Parameters Take Effect at Next VolumeChange/Login

3.9.3 EtherNet Config

To set the Ethernet configuration, click the **EtherNet Config** link under the System Controls menu. The RAID subsystem EtherNet Configuration screen will be shown. Set the desired configuration. Once done, tick on the **Confirm The Operation** and click the **Submit** button to save the settings.

Ether Net Configurations	
DHCP Function	Disabled
Local IP Address (Used If DHCP Disabled)	192 .168 .1 .109
Gateway IP Address (Used If DHCP Disabled)	192 .168 .1 .1
Subnet Mask (Used If DHCP Disabled)	255 .255 .255 .0
HTTP Port Number (7168..8191 Is Reserved)	80
Telnet Port Number (7168..8191 Is Reserved)	23
SMTP Port Number (7168..8191 Is Reserved)	25
iSCSI Port Number (7168..8191 Is Reserved)	3260
AoE Major Address (0..4094)	1292
Current IP Address	192.168.1.109
Current Gateway IP Address	192.168.1.1
Current Subnet Mask	255.255.255.0
Ether Net MAC Address	00.1B.4D.01.25.0A

Confirm The Operation

Submit Reset

DHCP Function

This option is used to disable or enable (Default is Enabled) the DHCP client function.

Local IP Address

This option is used to configure the R-Link IP address, if DHCP is disabled.

Gateway IP Address

This option is used to configure the R-Link IP gateway IP address, if DHCP is disabled.

Subnet Mask

This option is used to configure the subnet mask, if DHCP is disabled.

HTTP Port Number

This option is used to set HTTP Port Number. Default is 80. Note that port number from 7168 to 8191 is reserved for system use.

Telnet Port Number

This option is used to set Telnet Port Number. Default is 23. Note that port number from 7168 to 8191 is reserved for system use.

SMTP Port Number

This option is used to set SMTP Port Number. Default is 25. Note that port number from 7168 to 8191 is reserved for system use.

iSCSI Port Number

This option is used to set iSCSI Port Number. Default is 3260. Port Number can also be changed in iSCSI Config. Note that port number from 7168 to 8191 is reserved for system use.

AoE Major Address

This option is used to set the AoE Header Major Address. Range is from 0 to 4094.

3.9.4 Alert By Mail Config

To set the Event Notification function, click on the **Alert By Mail Config** link under the System Controls main menu. The RAID subsystem Event Notification configuration screen will be shown. Set up the desired function and option. When an abnormal condition occurs, an error message will be emailed to the email recipient(s) that a problem has occurred. Events are classified into 4 levels (Urgent, Serious, Warning, and Information).

The screenshot shows the RAID Manager web interface. The left sidebar contains a navigation menu with the following items:

- Quick Function
- RaidSet Functions
- VolumeSet Functions
- Physical Drives
- System Controls
 - System Config
 - iSCSI Config
 - EtherNet Config
 - Alert By Mail Config**
 - SNMP Configuration
 - NTP Configuration
 - View Events/Mute Beeper
 - Generate Test Event
 - Clear Event Buffer
 - Modify Password
 - Upgrade Firmware
 - Shutdown Controller
 - Restart Controller
- Information

The main content area is titled "RAID Manager" and displays the "Alert By Mail Config" page. The page is divided into three main sections:

SMTP Server Configuration

SMTP Server IP Address:

Mail Address Configurations

Sender Name: Mail Address:
 Account: Password:

MailTo Name1: Mail Address:
 MailTo Name2: Mail Address:
 MailTo Name3: Mail Address:
 MailTo Name4: Mail Address:

Event Notification Configurations

<input checked="" type="radio"/> Disable Event Notification	No Event Notification Will Be Sent
<input type="radio"/> Urgent Error Notification	Send Only Urgent Event
<input type="radio"/> Serious Error Notification	Send Urgent And Serious Event
<input type="radio"/> Warning Error Notification	Send Urgent, Serious And Warning Event
<input type="radio"/> Information Notification	Send All Event

3.9.5 SNMP Configuration

The SNMP gives users independence from the proprietary network management schemes of some manufacturers and SNMP is supported by many WAN and LAN manufacturers enabling true LAN/ WAN management integration.

To set the SNMP function, move the cursor to the main menu and click on the **SNMP Configuration** link. The RAID subsystem's SNMP Configurations screen will be shown. Select the desired function and set the preferred option.

RAID Manager XXXXXXXX

SNMP Trap Configurations

SNMP Trap IP Address #1	0	0	0	0	Port#	162
SNMP Trap IP Address #2	0	0	0	0	Port#	162
SNMP Trap IP Address #3	0	0	0	0	Port#	162

SNMP System Configurations

Community	
sysContact.0	
sysName.0	
sysLocation.0	

SNMP Trap Notification Configurations

<input checked="" type="radio"/> Disable SNMP Trap	No SNMP Trap Will Be Sent
<input type="radio"/> Urgent Error Notification	Send Only Urgent Event
<input type="radio"/> Serious Error Notification	Send Urgent And Serious Event
<input type="radio"/> Warning Error Notification	Send Urgent, Serious And Warning Event
<input type="radio"/> Information Notification	Send All Event

Confirm The Operation

Submit Reset

SNMP Trap Configurations: Type the SNMP Trap IP Address. The SNMP Port is set to 162 by default.

SNMP System Configuration:

Community: The default is Public.

(1)sysContact.0; (2)sysLocation.0; (3)sysName.0: SNMP parameter (31 bytes max). If these 3 categories are configured and when an error occurs, SNMP will send out a message that includes the 3 categories within the message. This allows user to easily define which RAID unit is having problem.

SNMP Trap Notification Configurations: Select the desired option.

After completing the settings, tick on the **Confirm The Operation** and click on the **Submit** button to save the configuration.

SNMP also works in the same as Alert By Mail when sending event notifications.

3.9.6 NTP Configuration

NTP stands for **Network Time Protocol**. It is an Internet protocol used to synchronize the clocks of computers to some time reference. Type the NTP Server IP Address to enable the RAID subsystem to synchronize with it.

To set the NTP function, move the cursor to the main menu and click on the **NTP Configuration**. The RAID subsystem's NTP Configuration screen will be displayed. Select the desired function and configure the necessary option.

After completing the settings, tick on the **Confirm The Operation** and click on the **Submit** button to save the configuration.

The screenshot displays the RAID Manager web interface for NTP configuration. The left sidebar lists various system control options, including 'NTP Configuration'. The main content area is titled 'RAID Manager XXXXXXXX' and is divided into several sections:

- NTP Server Configurations:** Contains two input fields for 'NTP Server IP Address #1' and 'NTP Server IP Address #2', each with four digit boxes (0, 0, 0, 0).
- Time Zone Configuration:** Includes a dropdown menu for 'Time Zone' (set to '(GMT+08:00)Taipei'), a dropdown for 'Automatic Daylight Saving' (set to 'Enabled'), and a text field for 'Current Time' (2009/8/24 11:43:11). Below this is a text field containing 'NTP Server Not Set'.
- Confirm The Operation:** A checkbox labeled 'Confirm The Operation' is present.
- Buttons:** 'Submit' and 'Reset' buttons are located at the bottom of the configuration area.

3.9.7 View Events/Mute Beeper

To view the RAID subsystem's event log information, move the mouse cursor to the System Controls menu and click on the System Information link. The Raid Subsystem's System Events Information screen appears.

The System Events Information screen will show: Time, Device, Event type, Elapse Time and Errors. The RAID system does not have built-in real time clock. When the RAID manager GUI is opened from a host system via R-Link connection, the RAID system's time will be referenced to the time of the host system. When not connected to the RAID Manager GUI via R-Link connection, the time information is the relative to the time when the RAID subsystem was powered on.

This function can also be used to silence the alarm beeper.

Time	Device	Event type	Elapse Time	Errors
2009-08-19 19:07:58	Volume---VOL#07	Start Rebuilding		
2009-08-19 19:07:58	Volume---VOL#06	Complete Rebuild	000:32:01	
2009-08-19 18:35:57	Volume---VOL#06	Start Rebuilding		
2009-08-19 18:35:57	Volume---VOL#05	Complete Rebuild	000:31:52	
2009-08-19 18:04:04	Volume---VOL#05	Start Rebuilding		
2009-08-19 18:04:04	Volume---VOL#04	Complete Rebuild	000:31:37	
2009-08-19 17:32:27	Volume---VOL#04	Start Rebuilding		
2009-08-19 17:32:27	Volume---VOL#03	Complete Rebuild	000:31:25	
2009-08-19 17:01:02	Volume---VOL#03	Start Rebuilding		
2009-08-19 17:01:02	Volume---VOL#02	Complete Rebuild	000:31:17	
2009-08-19 16:29:44	Volume---VOL#02	Start Rebuilding		
2009-08-19 16:29:44	Volume---VOL#01	Complete Rebuild	000:31:10	
2009-08-19 15:58:34	Volume---VOL#01	Start Rebuilding		
2009-08-19 15:58:34	Volume---VOL#00	Complete Rebuild	000:30:59	
2009-08-19 15:27:34	Volume---VOL#00	Start Rebuilding		
2009-08-19 15:27:34	Raid Set # 00	Rebuild RaidSet		
2009-08-19 15:27:34	IDE Channel 4	Device Inserted		
2009-08-19 15:27:27	IDE Channel 4	Device Removed		
2009-08-19 15:27:27	Raid Set # 00	RaidSet Degraded		
2009-08-19 15:27:27	Volume---VOL#07	Volume Degraded		
2009-08-19 15:27:27	Volume---VOL#06	Volume Degraded		
2009-08-19 15:27:27	Volume---VOL#05	Volume Degraded		
2009-08-19 15:27:27	Volume---VOL#04	Volume Degraded		

3.9.8 Generate Test Event

If you want to generate test events, move the mouse cursor to the main menu and click on the **Generate Test Events** Link. Tick on the **Confirm The Operation** and click on the **Submit** button. Then click on the **View Events/Mute Beeper** to view the test event.

The screenshot shows the RAID Manager web interface. On the left is a navigation menu with categories: Quick Function, RaidSet Functions, VolumeSet Functions, Physical Drives, System Controls, and Information. Under System Controls, 'Generate Test Event' is highlighted. The main content area displays the RAID Manager logo and a confirmation dialog box titled 'Do You Want To Generate Test Event?'. The dialog has a checked checkbox for 'Confirm The Operation' and two buttons: 'Submit' and 'Reset'.

The screenshot shows the RAID Manager web interface with the 'View Events/Mute Beeper' option selected in the navigation menu. The main content area displays the RAID Manager logo and a table titled 'System Events Information'. The table lists various system events with columns for Time, Device, Event Type, Elapse Time, and Errors.

Time	Device	Event Type	Elapse Time	Errors
2009-08-24 11:48:17	H/W Monitor	Test Event		
2009-08-24 11:47:57	192.168.002.032	HTTP Log In		
2009-08-24 11:46:11	192.168.002.190	HTTP Log In		
2009-08-24 11:45:52	192.168.002.032	HTTP Log In		
2009-08-24 11:36:05	192.168.002.032	HTTP Log In		
2009-08-22 20:40:21	Volume---VOL#02	Delete Volume		
2009-08-22 20:40:05	Volume---VOL#01	Delete Volume		
2009-08-22 20:40:01	Volume---VOL#00	Delete Volume		
2009-08-22 19:42:34	192.168.002.020	HTTP Log In		
2009-08-22 18:54:39	H/W Monitor	Raid Powered On		
2009-08-22 18:53:52	Volume---VOL#00	Create Volume		
2009-08-22 18:53:35	Volume---VOL#00	Delete Volume		
2009-08-22 15:09:09	192.168.002.020	HTTP Log In		
2009-08-22 15:05:31	H/W Monitor	Raid Powered On		
2009-08-21 17:39:05	Volume---VOL#02	Create Volume		

3.9.9 Clear Event Buffer

Use this feature to clear the RAID subsystem's System Events Information buffer.

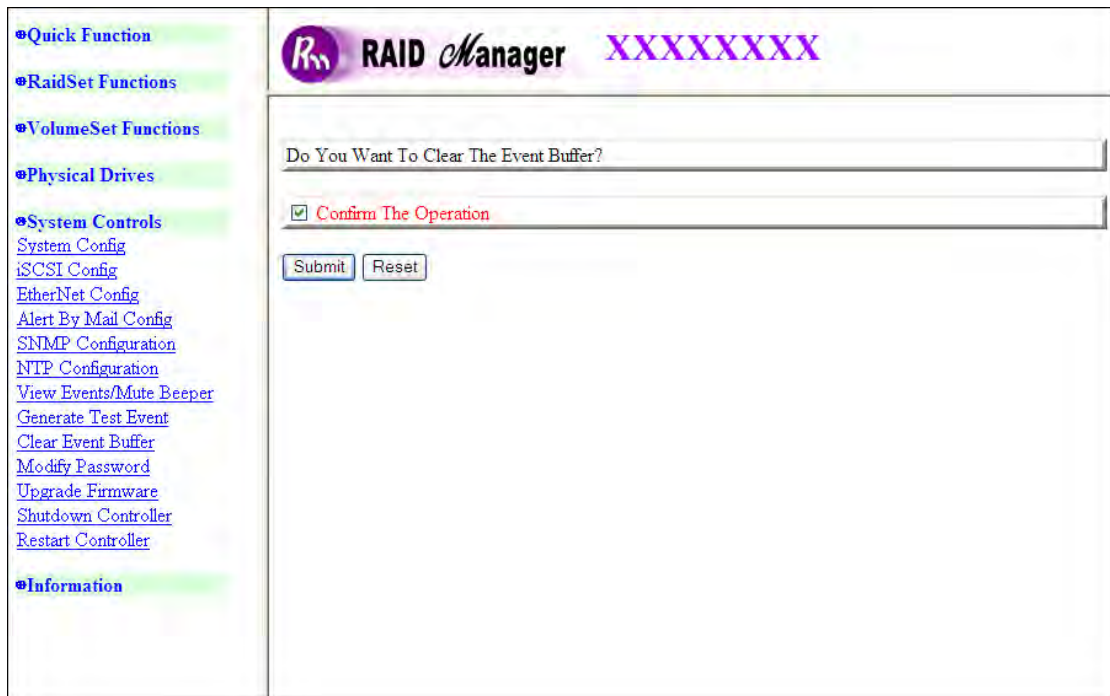

3.9.10 Modify Password

To change or disable the RAID subsystem's admin password, click on the **Change Password** link under the **System Controls** menu. The Modify System Password screen appears.

The factory-default admin password is set to **00000000**. Once the password has been set, the user or administrator can only monitor and configure the RAID subsystem by providing the correct password.

The password is used to protect the RAID subsystem's configuration from unauthorized access. The RAID controller will check the password only when entering the Main Menu from the initial screen. The RAID subsystem will automatically go back to the initial screen when it does not receive any command after sometime.

To disable the password, enter only the original password in the **Enter Original Password** box, leave both the **Enter New Password** and **Re-Enter New Password** boxes blank. After selecting the **Confirm The Operation** option and clicking the **Submit** button, the system password checking will be disabled. No password checking will occur when entering the main menu from the starting screen.

The screenshot displays the RAID Manager web interface. On the left is a navigation menu with the following items:

- Quick Function
- RaidSet Functions
- VolumeSet Functions
- Physical Drives
- System Controls
 - System Config
 - iSCSI Config
 - EtherNet Config
 - Alert By Mail Config
 - SNMP Configuration
 - NTP Configuration
 - View Events/Mute Beeper
 - Generate Test Event
 - Clear Event Buffer
 - Modify Password
 - Upgrade Firmware
 - Shutdown Controller
 - Restart Controller
- Information

The main content area features the RAID Manager logo and a title bar with the text "Modify System Password". Below the title bar are three input fields:

- Enter Original Password
- Enter New Password
- Re-Enter New Password

Below the input fields is a checkbox labeled "Confirm The Operation" and two buttons: "Submit" and "Reset".

3.9.11 Upgrade Firmware

Please refer to Section 3.12 for more information.

3.9.12 Shutdown Controller

Use this function to shutdown the RAID Controller. This is used to flush the data from the cache memory, and is normally done before powering off the subsystem.

<ul style="list-style-type: none">● Quick Function● RaidSet Functions● VolumeSet Functions● Physical Drives● System Controls<ul style="list-style-type: none">System ConfigiSCSI ConfigEtherNet ConfigAlert By Mail ConfigSNMP ConfigurationNTP ConfigurationView Events/Mute BeeperGenerate Test EventClear Event BufferModify PasswordUpgrade FirmwareShutdown ControllerRestart Controller● Information	 RAID Manager XXXXXXXX
	<input type="checkbox"/> Confirm To Shutdown Controller <input type="button" value="Submit"/> <input type="button" value="Reset"/>

3.9.13 Restart Controller

Use this function to restart the RAID controller.

<ul style="list-style-type: none">● Quick Function● RaidSet Functions● VolumeSet Functions● Physical Drives● System Controls<ul style="list-style-type: none">System ConfigiSCSI ConfigEtherNet ConfigAlert By Mail ConfigSNMP ConfigurationNTP ConfigurationView Events/Mute BeeperGenerate Test EventClear Event BufferModify PasswordUpgrade FirmwareShutdown ControllerRestart Controller● Information	 RAID Manager XXXXXXXX
	<input type="checkbox"/> Confirm To Restart Controller <input type="button" value="Submit"/> <input type="button" value="Reset"/>

3.10 Information Menu

3.10.1 RaidSet Hierarchy

Use this feature to view the RAID subsystem's existing Raid Set(s), Volume Set(s) and physical disk(s) configuration and information. Select the **RaidSet Hierarchy** link from the **Information** menu to display the Raid Set Hierarchy screen..

Raid Set	IDE Channels	Volume Set(Ch/Drv#)	Volume State	Capacity
Raid Set # 00	Ch01	Volume---VOL#00 (0&1:0)	Normal	263.0GB
	Ch02	Volume---VOL#01 (0&1:1)	Normal	263.0GB
	Ch03	Volume---VOL#02 (0&1:2)	Normal	263.0GB
	Ch04	Volume---VOL#03 (0&1:3)	Normal	263.0GB
	Ch05	Volume---VOL#04 (0&1:4)	Normal	263.0GB
	Ch06	Volume---VOL#05 (0&1:5)	Normal	263.0GB
	Ch07	Volume---VOL#06 (0&1:6)	Normal	263.0GB
	Ch08	Volume---VOL#07 (0&1:7)	Normal	215.6GB

Channel	Usage	Capacity	Model
Ch01	Raid Set # 00	300.1GB	WDC WD3000HLFS-01G6U0
Ch02	Raid Set # 00	300.1GB	WDC WD3000HLFS-01G6U0
Ch03	Raid Set # 00	300.1GB	WDC WD3000HLFS-01G6U0
Ch04	Raid Set # 00	300.1GB	WDC WD3000HLFS-01G6U0
Ch05	Raid Set # 00	300.1GB	WDC WD3000HLFS-01G6U0
Ch06	Raid Set # 00	300.1GB	WDC WD3000HLFS-01G6U0
Ch07	Raid Set # 00	300.1GB	WDC WD3000HLFS-01G6U0
Ch08	Raid Set # 00	300.1GB	WDC WD3000HLFS-01G6U0

To view the Raid Set information, click the **Raid Set #** link from the Raid Set Hierarchy screen. The Raid Set Information screen appears.

Raid Set Information	
Raid Set Name	Raid Set # 00
Member Disks	8
Total Raw Capacity	2400.6GB
Free Raw Capacity	0.0GB
Min Member Disk Size	300.1GB
Raid Set Power State	Operating
Raid Set State	Normal

To view the disk drive information, click the **CHO#** link from the Raid Set Hierarchy screen. The Disk Information screen appears. This screen shows various information such as timeout count, media error count, and SMART information.

The SMART information shows two numbers, one on the left (attribute value) and one on the right enclosed in parentheses (threshold). The higher the attribute value is compared to the threshold value, the better. If the attribute value becomes smaller than the threshold value, the disk is in unstable state.

The screenshot shows the RAID Manager interface with the 'IDE Drive Information' tab selected. The left sidebar contains navigation options: Quick Function, RaidSet Functions, VolumeSet Functions, Physical Drives, System Controls, and Information (with sub-links for RaidSet Hierarchy, System Information, and Hardware Monitor). The main area displays the RAID Manager logo and 'XXXXXXXX' in purple. Below the title bar is a table of IDE Drive Information.

IDE Drive Information	
IDE Channel	1
Model Name	WDC WD3000HLFS-01G6U0
Serial Number	WD-WXLY08094834
Firmware Rev.	04.04V01
Disk Capacity	300.1GB
Current SATA Mode	SATA300
Supported SATA Mode	SATA300+NCQ(Depth32)
Device State	Normal
Timeout Count	0
Media Error Count	0
SMART Read Error Rate	200(51)
SMART Spinup Time	198(21)
SMART Reallocation Count	200(140)
SMART Seek Error Rate	200(0)
SMART Spinup Retries	100(0)
SMART Calibration Retries	100(0)

The SMART Attribute(Threshold) Is A Normalized Value, The Value Is The Larger The Better.
If The Attribute Value Is Smaller Than The Threshold Value, The Disk Is In Unstable State.

To view the Volume Set information, click the **Volume Set #** link from the Raid Set Hierarchy screen. The Volume Set Information screen appears.

The screenshot shows the RAID Manager interface with the 'Volume Set Information' tab selected. The left sidebar is identical to the previous screenshot. The main area displays the RAID Manager logo and 'XXXXXXXX' in purple. Below the title bar is a table of Volume Set Information.

Volume Set Information	
Volume Set Name	Volume---VOL#00
Raid Set Name	Raid Set # 00
Volume Capacity	263.0GB
Channel Drv#	SATA&USB 0
Raid Level	Raid 5
Stripe Size	64KBytes
Member Disks	8
Cache Mode	Write Back
SATA Data Xfer Mode	SATA300+NCQ
Current SATA Xfer Mode	Not Linked
Current USB Xfer Mode	Not Linked
Volume State	Normal

3.10.2 System Information

To view the RAID subsystem's controller information, click the **System Information** link from the **Information** menu. The Raid Subsystem Information screen appears.

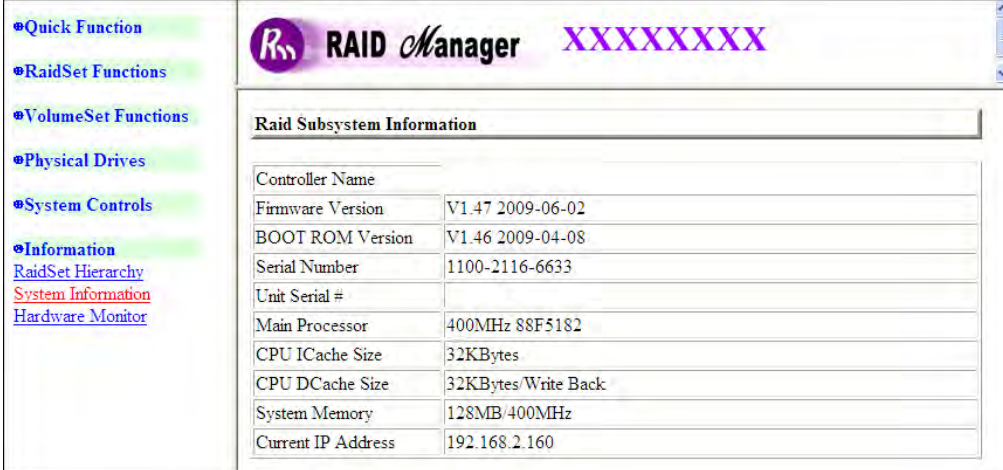

Raid Subsystem Information	
Controller Name	
Firmware Version	V1.47 2009-06-02
BOOT ROM Version	V1.46 2009-04-08
Serial Number	1100-2116-6633
Unit Serial #	
Main Processor	400MHz 88F5182
CPU ICache Size	32KBytes
CPU DCache Size	32KBytes/Write Back
System Memory	128MB 400MHz
Current IP Address	192.168.2.160

The controller name, firmware version, serial number, main processor, CPU data/instruction cache size and system memory size/speed appear in this screen.

3.10.3 Hardware Monitor

To view the RAID subsystem's controller hardware information, click the **Hardware Monitor** link from the **Information** menu. The Hardware Monitor Information screen appears.

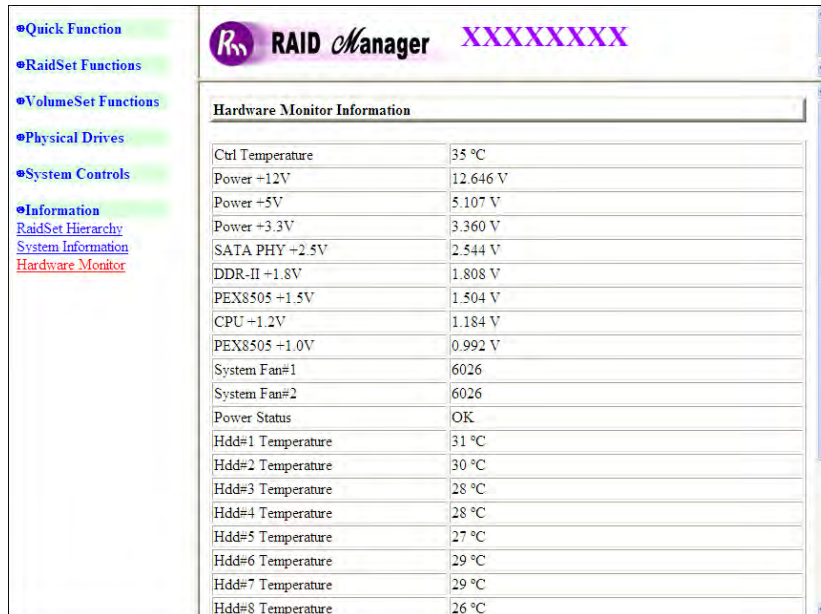

Hardware Monitor Information	
Ctrl Temperature	35 °C
Power +12V	12.646 V
Power +5V	5.107 V
Power +3.3V	3.360 V
SATA PHY +2.5V	2.544 V
DDR-II +1.8V	1.808 V
PEX8505 +1.5V	1.504 V
CPU +1.2V	1.184 V
PEX8505 +1.0V	0.992 V
System Fan#1	6026
System Fan#2	6026
Power Status	OK
Hdd#1 Temperature	31 °C
Hdd#2 Temperature	30 °C
Hdd#3 Temperature	28 °C
Hdd#4 Temperature	28 °C
Hdd#5 Temperature	27 °C
Hdd#6 Temperature	29 °C
Hdd#7 Temperature	29 °C
Hdd#8 Temperature	26 °C



NOTE: When no disk drive is installed in the disk slot, the disk temperature will show "--". The disk temperature will also show "--" when "HDD SMART Status Polling" is disabled in System Configuration.

The Hardware Monitor Information provides the temperature and voltage levels of the RAID subsystem. All items are also unchangeable. When the threshold values are exceeded, warning messages will be indicated through the LCD, LED and alarm buzzer.

Item	Warning Condition
Controller Board Temperature	> 60 Celsius
HDD Temperature	> 60 Celsius
Power Supply +12V	< 10.5V or > 13.5V
Power Supply +5V	< 4.7V or > 5.4V
Power Supply +3.3V	< 3.0V or > 3.6V
DDR Supply Voltage +2.5V	< 2.25V or > 2.75V
CPU Core Voltage +1.3V	< 1.17V or > 1.43V
DDR Termination Power +1.25V	< 1.125V or > 1.375V

3.11 Creating New Raid Set or Reconfiguring an Existing Raid Set

You can configure Raid Sets and Volume Sets using **Quick Create** or **Raid Set Functions/Volume Set Functions** configuration method. Each configuration method requires a different level of user input. The general flow of operations for Raid Set and Volume Set configuration is:

Step	Action
1	Designate hot spare disk/pass-through disk (optional).
2	Choose a configuration method.
3	Create Raid Set using the available physical drives.
4	Define Volume Set using the available raw capacity in the Raid
5	Initialize the Volume Set. Then use Volume Set in the Host OS.

3.12 Upgrading the Firmware

Upgrading Firmware Using Flash Programming Utility

Since the RAID subsystem's controller features flash firmware, it is not necessary to change the hardware flash chip in order to upgrade the controller firmware. User can simply re-program the old firmware through the RS-232 port. New releases of the firmware are available in the form of binary file at vendor's FTP. The file available at the FTP site is usually a self-extracting file that contains the following:

XXXXVVV.BIN Firmware Binary (where "XXXX" refers to the model name and "VVV" refers to the firmware version)

README.TXT It contains the history information of the firmware change. Read this file first before upgrading the firmware.

These files must be extracted from the compressed file and copied to one directory in the host computer.

Establishing the Connection for the RS-232

The firmware can be downloaded to the RAID subsystem's controller using an ANSI/VT-100 compatible terminal emulation program or web browser-based RAID Manager remote management page.

With terminal emulation program, you must complete the appropriate installation and configuration procedure before proceeding with the firmware upgrade. Whichever terminal emulation program is used must support the ZMODEM file transfer protocol.

Web browser-based RAID Manager can be used to update the firmware. A web browser must have been installed and setup before proceeding with the firmware upgrade.

Upgrading Firmware Through ANSI/VT-100 Terminal Emulation

Get the new firmware version for your RAID subsystem controller. For Example, download the bin file from your vendor's web site into the local directory.



NOTE: When there is new boot ROM firmware that needs to be upgraded, upgrade first the boot ROM firmware. Then repeat the process (steps 1 to 9) to upgrade the firmware code after which a RAID controller restart will be necessary.

1. From the Main Menu, scroll down to "Raid System Function"
2. Choose the "Update Firmware". The **Update The Raid Firmware** dialog box appears.

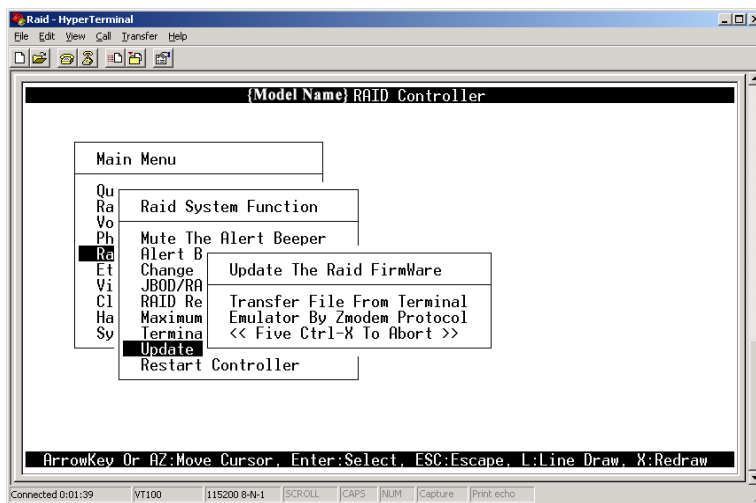

3. Go to the menu bar and click **Transfer**. Select **Send File**.

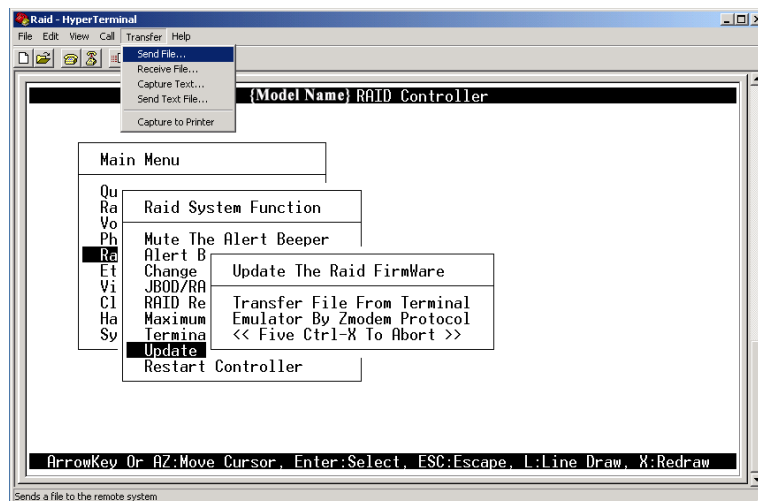

4. Select "ZMODEM modem" under Protocol to set ZMODEM as the file transfer protocol of your terminal emulation software.
5. Click Browse. Look in the location where the firmware file was saved. Select the firmware file name "xxxxxxx.BIN" and click Open.

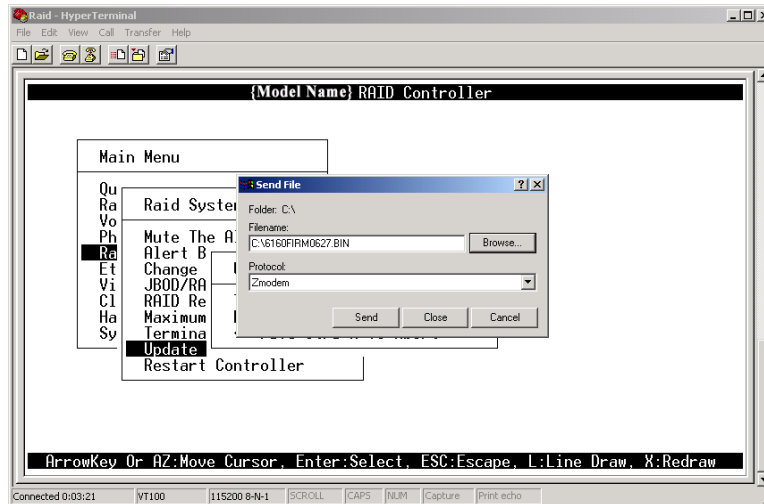

6. Click Send to send the firmware binary file to the RAID controller.

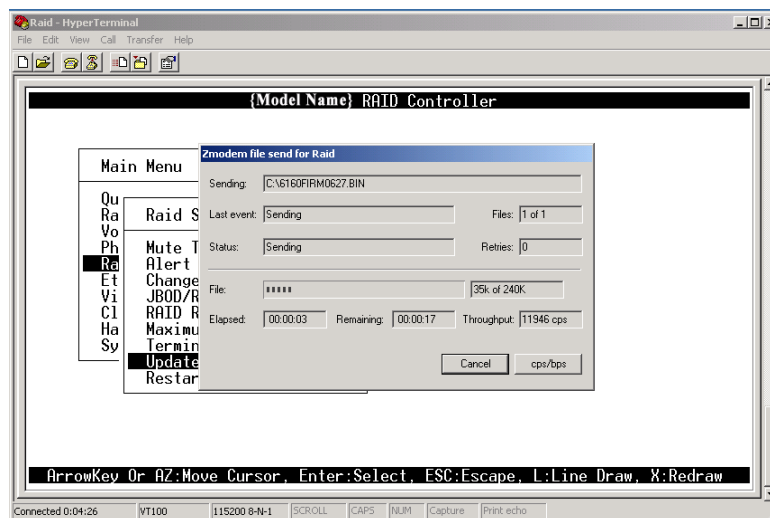

7. When the firmware downloading is completed, the confirmation screen appears. Select Yes to start programming the flash ROM.

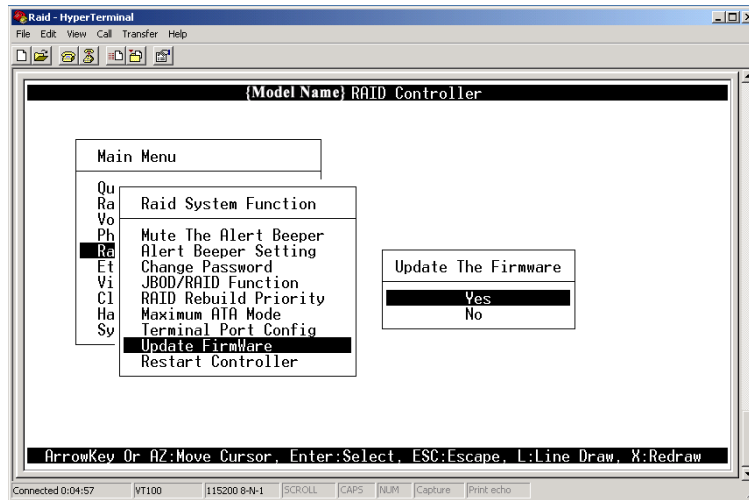

8. When the Flash programming starts, a message will show " Start Updating Firmware. Please Wait".

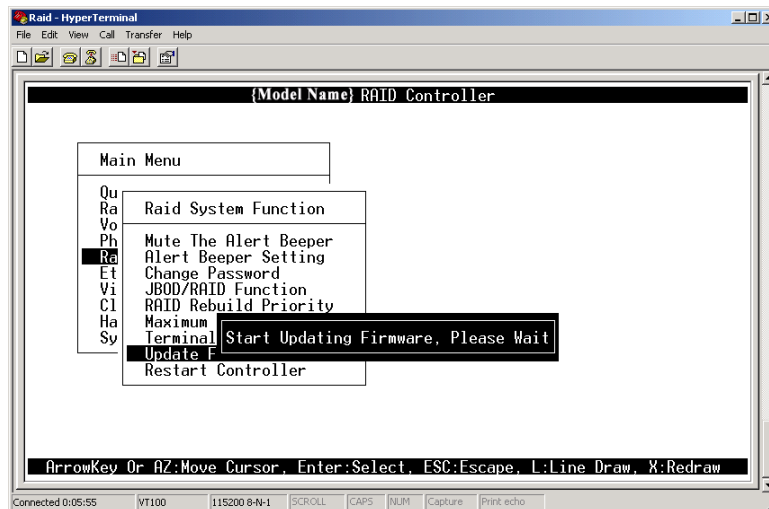

9. The firmware upgrade will take approximately thirty seconds to complete.

- After the firmware upgrade is complete, a message will show "Firmware Has Been Updated Successfully". Restarting the RAID controller is required for the new firmware to take effect.

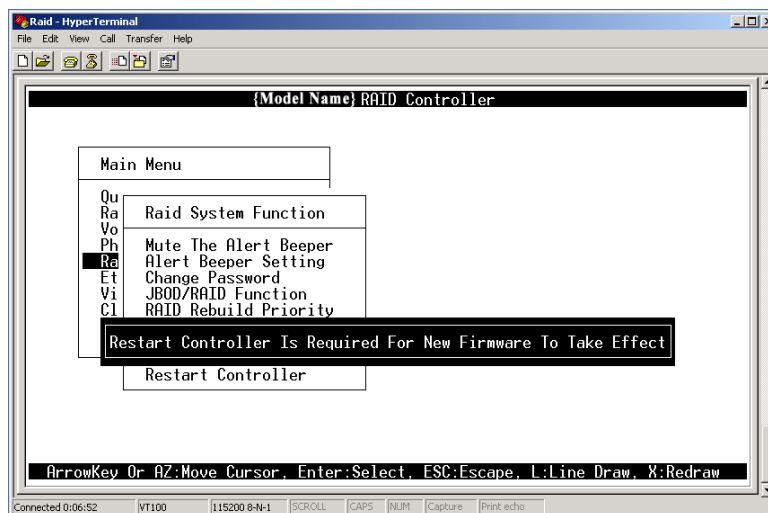
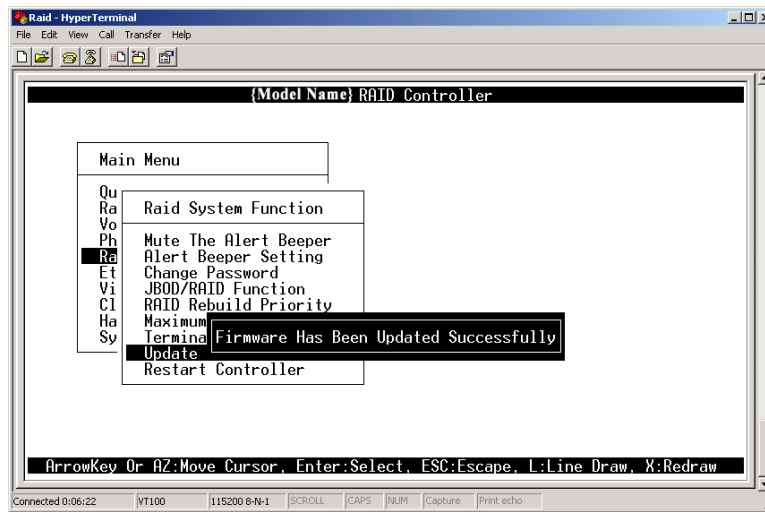

Upgrading Firmware Through Web Browser

Get the new version of firmware for your RAID subsystem controller.



NOTE: When there is new boot ROM firmware that needs to be upgraded, upgrade first the boot ROM firmware. Then repeat the process (steps 1 to 3) to upgrade the firmware code after which a RAID controller restart will be necessary.

1. To upgrade the RAID subsystem firmware, click the **Upgrade Firmware** link under **System Controls** menu. The Upgrade The Raid System Firmware Or Boot Rom screen appears.
2. Click **Browse**. Look in the location where the firmware file was saved. Select the firmware file name "xxxxxxx.BIN" and click Open.

3. Select the **Confirm The Operation** option. Click the **Submit** button.
4. The Web Browser begins to download the firmware binary to the controller and start to update the flash ROM.
5. After the firmware upgrade is complete, a message will show "Firmware Has Been Updated Successfully". Restarting the RAID controller is required for the new firmware to take effect.

Chapter 4 Appendix

4.1 Upgrading from Single Power Supply Mode to Redundant Mode (Optional)



NOTE: If Raid subsystem is in Single Power Supply Mode and customer wants to upgrade to Redundant Power Supply Mode, the other Power Supply Module can be purchased. Please contact your storage vendor.

To upgrade from single power supply mode to redundant power supply mode, follow these steps:

1. Loosen the two screws of the power supply cover plate.



2. Remove the cover plate and insert power supply carefully. Tighten two screws to lock the power supply in place.



3. Change the toggle switch to RPW indicating that the power supply is in redundant mode.

